

This is an electronic reprint of the original article.

This reprint *may differ* from the original in pagination and typographic detail.

Author(s): Jenni Tienaho, Jaana Liimatainen, Laura Myllymäki, Kalle Kaipainen, Luca Tagliavento, Kyösti Ruuttunen, Magnus Rudolfsson, Maarit Karonen, Varpu Marjomäki, Ann E. Hagerman, Tuula Jyske, Francesco Meneguzzo, Petri Kilpeläinen

Title: Pilot scale hydrodynamic cavitation and hot-water extraction of Norway spruce bark yield antimicrobial and polyphenol-rich fractions

Year: 2025

Version: Published version

Copyright: The Author(s) 2025

Rights: CC BY 4.0

Rights url: <https://creativecommons.org/licenses/by/4.0/>

Please cite the original version:

Jenni Tienaho, Jaana Liimatainen, Laura Myllymäki, Kalle Kaipainen, Luca Tagliavento, Kyösti Ruuttunen, Magnus Rudolfsson, Maarit Karonen, Varpu Marjomäki, Ann E. Hagerman, Tuula Jyske, Francesco Meneguzzo, Petri Kilpeläinen, Pilot scale hydrodynamic cavitation and hot-water extraction of Norway spruce bark yield antimicrobial and polyphenol-rich fractions, Separation and Purification Technology, Volume 360, Part 1, 2025, 130925, ISSN 1383-5866, <https://doi.org/10.1016/j.seppur.2024.130925> .

All material supplied via *Jukuri* is protected by copyright and other intellectual property rights. Duplication or sale, in electronic or print form, of any part of the repository collections is prohibited. Making electronic or print copies of the material is permitted only for your own personal use or for educational purposes. For other purposes, this article may be used in accordance with the publisher's terms. There may be differences between this version and the publisher's version. You are advised to cite the publisher's version.



Pilot scale hydrodynamic cavitation and hot-water extraction of Norway spruce bark yield antimicrobial and polyphenol-rich fractions

Jenni Tienaho^{a,*}, Jaana Liimatainen^a, Laura Myllymäki^b, Kalle Kaipanen^a, Luca Tagliavento^c,
Kyösti Ruuttunen^a, Magnus Rudolfsson^d, Maarit Karonen^e, Varpu Marjomäki^b,
Ann E. Hagerman^f, Tuula Jyske^{a,g}, Francesco Meneguzzo^{h,1}, Petri Kilpeläinen^{a,1}

^a Production Systems, Natural Resources Institute Finland (Luke), Latokartanonkaari 9, FI-00790 Helsinki, Finland

^b Department of Biological and Environmental Science, Nanoscience Center, University of Jyväskylä, FI-40014 Jyväskylä, Finland

^c HyRes S.r.l, Via Salvator Rosa 18, I-82100 Benevento, Italy

^d Swedish University of Agricultural Sciences, Unit of Biomass Technology and Chemistry, SE-90183 Umeå, Sweden

^e Natural Chemistry Research Group, Department of Chemistry, University of Turku, FI-20014 Turku, Finland

^f Department of Chemistry and Biochemistry, Miami University, Oxford, OH 45056, United States

^g Department of Forest Sciences, University of Helsinki, PO Box 27 (Latokartanonkaari 7), FI-00014, Helsinki, Finland

^h Institute of Bioeconomy, National Research Council of Italy, 10 Via Madonna del Piano, I-50019 Florence, Italy

ARTICLE INFO

Editor: M Freire

Keywords:
Bioactive
Hot-water extraction
Hydrodynamic cavitation
Industrial assortment
Norway spruce bark
Polyphenols

ABSTRACT

Norway spruce (*Picea abies* [L.] Karst) tree bark contains high concentrations of polyphenolic compounds with antibacterial, antioxidant, and antiviral properties. While laboratory-scale extraction studies are relatively abundant, the behavior of biomass properties and compound profiles during upscaled processing have remained underexplored. This study addresses the gap by assessing the industrial feasibility of using an industrial-scale assortment of bark biomass obtained directly from a sawmill. It compares two green pilot-scale extraction methods using only water as the solvent: hydrodynamic cavitation and hot-water extraction. The resulting lyophilized and spray-dried extracts were analyzed for their antibacterial, antiviral, and antioxidant activities, as well as their chemical composition, including carbohydrate, stilbene, tannin, and terpene contents. To further evaluate the industrial potential, a technical feasibility analysis was conducted, highlighting material and energy balances for both extraction processes and identifying areas for improvement. The findings indicate that both extraction methods effectively yielded polyphenol-rich extracts with desirable bioactivities. Notably, hot-water extracts, with slightly higher condensed tannin and stilbene content, exhibited higher antioxidant activity and greater efficacy against enterovirus (coxsackievirus A9), while hydrodynamic cavitation products showed higher activity against gram-positive and gram-negative bacteria. Lyophilization resulted in slightly lower chain-length, but higher concentrations of tannins and stilbenes compared to spray-drying. Overall, this study demonstrates that upscaled processing of spruce bark can effectively and sustainably produce commercially viable extraction products.

1. Introduction

During recent years, the sustainable utilization of natural resources, especially byproducts of industrial supply chains, has attracted attention as a source for the extraction of bioactive compounds with potential industrial applications. Norway spruce (*Picea abies* [L.] Karst) has significant ecological and economical importance and is valued for its high-quality timber and utilized for pulp and paper. Debarking of stemwood

at the saw and pulp mills results in a remarkable annual amount of spruce bark sidestreams. In Finland alone, 6–7 million m³ of bark is produced per year [1]. To date, most of this renewable and abundant bark biomass is combusted for heat and energy, leaving most of its potential unutilized, while bark is known to contain various beneficial compounds endowed with biological activities [2].

Conifer bark acts as the protective barrier of the tree and shields against different abiotic and biotic stressors. Bark is known to contain

* Corresponding author.

E-mail address: jenni.tienaho@luke.fi (J. Tienaho).

¹ These authors have contributed equally.

several secondary metabolites – extractives, and their production is activated during the plant's defense mechanism and combat against pathogens [3]. Spruce bark has been extensively studied and is known to contain various phytochemical constituents with beneficial properties. Such constituents with antimicrobial and/or antioxidant activities include e.g., terpenoids [4], polyphenols such as stilbenes [5] and tannins [6], as well as resin acids [7]. In addition, lignans have been witnessed in the callus resin produced by wounded or damaged conifer trees [8], heart and knotwood [9] as well as root neck of Norway spruce [10].

In a recent comprehensive technical and economic study, a new biorefinery concept was advanced for the processing of spruce bark, aimed at implementing circular bioeconomy and increasing the value in the pulp and paper mills supply chain, including the forestry side [2]. It was suggested to exploit the content of stilbenoids (up to 7 w/w%) as natural anti-UV agents, and high-value pectin (up to 10 w/w%) as a common food and pharmaceutical ingredient, by means of selective extraction and purification. Of note, the laboratory-scale extraction processes included a Soxhlet step to remove the lipophilic molecules, as well as an ultrafiltration step to remove most of high molecular weight polyphenols (e.g., flavonoid-derived condensed tannins).

However, there is more to spruce bark than stilbenoids and pectin, in particular higher molecular weight polyphenols such as tannins and lignin, and lipophilic volatiles, which possess plenty of biological functions [11–13]. Thus, integral extracts hold promises for broader spectrum biological effects than purified substances, as well as allowing simpler and greener processes, and lower energy consumption.

Our hypotheses are that 1) industrial assortment and pilot-scale extraction can be used to obtain valuable compounds with broad bioactivities, 2) extraction conditions affect both the compound composition and bioactivity profile of the spruce bark extracts, 3) it is possible to further upscale the extraction processes from pilot to industrial scale. To test the hypotheses, this study focused on two green pilot-scale methods of integral extraction of Norway spruce bark, namely the emerging hydrodynamic cavitation (HC), and the better established hot-water extraction (HW). We investigated the extracts for their chemical constituents, such as condensed tannins, stilbenoids, terpenoids, and carbohydrates, and determined their antimicrobial and antioxidant activities. By scaling up the extraction process, we aim to bridge the gap between laboratory-scale investigations and industrial applicability, providing valuable insights into the feasibility of large-scale production of bioactive fractions from Norway spruce bark.

The relevance of this study derives from the processed resource, Norway spruce bark, which is a byproduct resulting from the highly developed timber supply chain on a continuous basis and in a great amount, whose large-scale sustainable exploitation could lead to important economic and environmental benefits. The main novelty of this study, besides the scale-up of the extraction processes and the technical feasibility analysis of their industrialization, results from the use, for the first time with Norway spruce bark, of HC as an emerging, green, and efficient extraction technique, as well as from the thorough analysis of the antimicrobial activity of the extracts.

2. Experimental

2.1. Sample collection

The spruce bark was collected on 22nd March 2023, at SCA Wood in Rundvig, Sweden (63.537445, 19.445812), directly from the outlet of the conveyer after the debarker and transported to Umeå, Biomass Technology Center (BTC), for shredding and milling during the same day. The shredded material was utilized in the hot-water extraction (HW) experiments, while the milled material was exploited in the hydrodynamic cavitation (HC) experiments. Shredding was performed in a Lindner Micromat MS 2000 equipped with a 30 mm sieve and milling was performed using a KlingMill ABs Multi Blade Shaft Mill (Peripheral

speed of the blades: 72 m/s; Feed setting: 7 Hz). To get a satisfactory size reduction of < 3 mm, milling was performed twice, and the material was then stored below 0 °C overnight before packing in 5 kg bags and transported frozen to the extraction facilities. Energy consumption of the sample collection and assortment is presented in Supplementary Table S1.

2.2. Bark extraction

Two different pilot-scale extraction methods were used, hydrodynamic cavitation and hot-water extraction. Both extractions were performed once and by using water as the extraction solvent. Evidence of predictability and reproducibility of the HW-based extraction process has been established [14]. HC-based extraction involves rather complex processes; however, their reproducibility in the field of the extraction of biomolecules from vegetable resources has also been confirmed [15].

In the hydrodynamic cavitation process, the mechanical energy from the pump heats up the liquid–solid mixture due to thermal conversion. Therefore, the mixture gradually heats from approximate room temperature and the cavitation process is ended at a given time and temperature. Hot-water extraction is a batch extraction method, where the pre-heated water is filled to the vessel and kept for a period. Specific details of the extraction equipment, especially for the HC unit, dictate the maximum allowed particle size and the solid-to-liquid ratio. The exact differences in the extraction procedures are explained below.

2.2.1. Hydrodynamic cavitation extraction (HC)

A milled spruce bark sample was extracted in water only, using a semi-industrial-scale (200 L) hydrodynamic cavitation (HC) pilot device optimized for food applications, previously used also for the extraction of silver fir needles [16]. Due to the use of a closed-impeller pump, to avoid clogging, particle size < 3 mm was used. The details of the HC-based extractor, comprising a closed hydraulic circuit with a centrifugal pump and a circular Venturi-shaped reactor as the key components, along with the meaning of the cavitation number as a measure of cavitation intensity and regime, were described in a previous study [17]. No active heat dissipation method was applied. Power and energy consumption were measured by means of a three-phase digital power meter (IME, Milan, Italy, model D4-Pd). A sample of 16 kg fresh biomass was extracted in 160 L of water. The extraction process started at 20 °C ($t = 0$ min) and the fresh biomass was slowly pitched into the system. The insertion ended after 16 min at 28.5 °C. Dry solids (DS%) content of the bark was 46.28 %, corresponding to about 7.4 kg of dry mass. The solid to liquid ratio was 1:22.8. During the process, a fairly stable cavitation number of 0.10 to 0.11 ensured optimal cavitation yield [18]. Four samples were collected, the last one after 48 min at the temperature of 47 °C.

2.2.2. Hot-water extraction (HW)

A shredded batch of 98.4 kg of fresh bark biomass, particle size < 30 mm, was loaded to the extraction vessel, along with 340 L of water. A very fine particle size (below 10 mm) clogs the extraction system, which is why a coarser fraction was needed. DS% of the bark was 46.28 %, corresponding to about 45.54 kg of dry mass. The solid to liquid ratio was 1:8.6. Water was pre heated to around 120 °C before filling the vessel. The temperature inside the vessel was 67 ± 6 °C during the extraction. The process lasted 60 min and after the extraction, solids and liquids were separated by passing the extract through a series of stainless steel meshes and decreasing mesh size down to 0.3 mm as previously described [19]. The extract was collected in an intermediate bulk container and weighed 143.2 kg. Total dissolved solids (TDS) of the extract were 2.81 %, as measured with an Ohaus MB90 IR-meter (China). Total DS in the collected extract was 4.02 kg. Brix 3.2 was measured with Bellingham & Stanley RFM712-M refractometer (UK).

Table 1 shows the basic features of the extraction processes, along with specific energy consumption, both fresh and dry basis, for each

Table 1

Bark extraction samples: HC = hydrodynamic cavitation extraction, HW = hot-water extraction.

Sample	Time (min)	T (°C)	Energy consumption (kwh/kg fresh)	Energy consumption (kwh/kg dry)
HC-1	16	28.5	0.126	0.272
HC-2	25	33	0.196	0.424
HC-3	35	39	0.275	0.594
HC-4	48	47	0.381	0.823
HW	60	67	1.243	2.686

collected sample. Fig. 1 emphasizes the differences between time and temperature of extraction processes.

2.3. Drying and handling

To separate the insoluble solid particles, all the sample extracts were similarly filtered with nylon (50 µm) filter bags (Eaton NMO-50-P03S, Hyxo, Finland) and then centrifugated at 4,816 g for 20 min. The contact time of the extracts with the nylon bag was kept as short as possible and no pressure was applied to minimize the possibility of reactions [20]. To determine the potential effect of drying, both freeze-drying and spray-drying were used for the supernatants. The spray-drying process was carried out using a pilot-scale spray-dryer (Mobile-minor; Niro Atomizer Co., Ltd., Copenhagen, Denmark) at an inlet temperature of 170 °C and an outlet temperature of 70 °C. Lyophilization was performed with Martin Christ Gefriertrocknungsanlagen GmbH, Freeze-dryer Beta 1-8LSCplus with Lyocube (Germany, 2020) with heated shelves set to 25 °C.

2.4. Biological activity analysis of extracts

2.4.1. Antibacterial analyses

The antibacterial properties of the extracts were assessed using *Escherichia coli* K12 + pcGLS11 (gram-negative) and *Staphylococcus aureus* RN4220 + pAT19 (gram-positive) that were genetically modified to emit a continuous luminescent signal as part of their normal metabolic processes [21]. When exposed to antibacterial substances, the

luminescent signal decreases, with the reduction being dependent on the concentration of the antibacterial agent. This methodology was reported in a previous study [22]. To initiate the experiments, strains stored at −80 °C were revived through approximately 16 h of cultivation at 30 °C (for *E. coli*) and 37 °C (for *S. aureus*) on lysogeny agar plates containing tryptone (10 g/L), yeast extract (5 g/L), NaCl (10 g/L), and agar (15 g/L). The *E. coli* plates were supplemented with 10 % (v/v) sterile filtered phosphate buffer (1 M, pH 7.0) and 100 µg/mL of ampicillin, while the *S. aureus* plates were supplemented with 5 µg/mL erythromycin. For preparation of stock solutions, a single colony of bacteria was inoculated into lysogeny broth with the same supplements and cultivated for approximately 16 h at 300 rpm shaking at 30 °C (*E. coli*) and 37 °C (*S. aureus*). Subsequently, all samples were diluted in water to achieve three concentrations ranging from 0.25 to 1 mg/mL per well of a microplate. Samples, along with positive controls (8.75 and 17.5 vol-% ethanol) and negative control (double-distilled water), were pipetted in triplicate into opaque white polystyrene microplates, with the same volume of bacterial inoculum added to each well. The resulting luminescent signal was measured using a Varioskan Flash Multilabel device (Thermo Fischer Scientific, Thermo Electron Co., Waltham, MA, USA) at room temperature every 5 min for 60 min, with the plate briefly shaken before each measurement. Results are expressed as inhibition percentages (inhibition%) relative to 1 mg/mL (dry weight of extracted biomass) after 50 min of incubation. Inhibition percentages were calculated using the formula: $\text{inhibition\%} = (1 - \text{RLU}_{\text{sample}} / \text{RLU}_{\text{neg. control}}) \times 100 \%$, where RLU represents relative light units obtained from the microplate reader.

2.4.2. Antiviral analyses

The antiviral properties of the bark extracts were tested against two different viruses obtained from the American Type of Culture Collection (ATCC, Manassa, VA, USA), the non-enveloped human coxsackievirus A9 (CVA9, Griggs strain, ATCC VR-186) and the enveloped seasonal human betacoronavirus 1 (HCoV-OC43 strain, ATCC VR-1558). The production and purification of CVA9 was performed following the protocol described by Myllynen et al. [23]. HCoV-OC43 was used as a crude extract.

The antiviral experiments against CVA9 were carried on using adenocarcinomic human lung cells (A549, ATCC CCL-185), while human

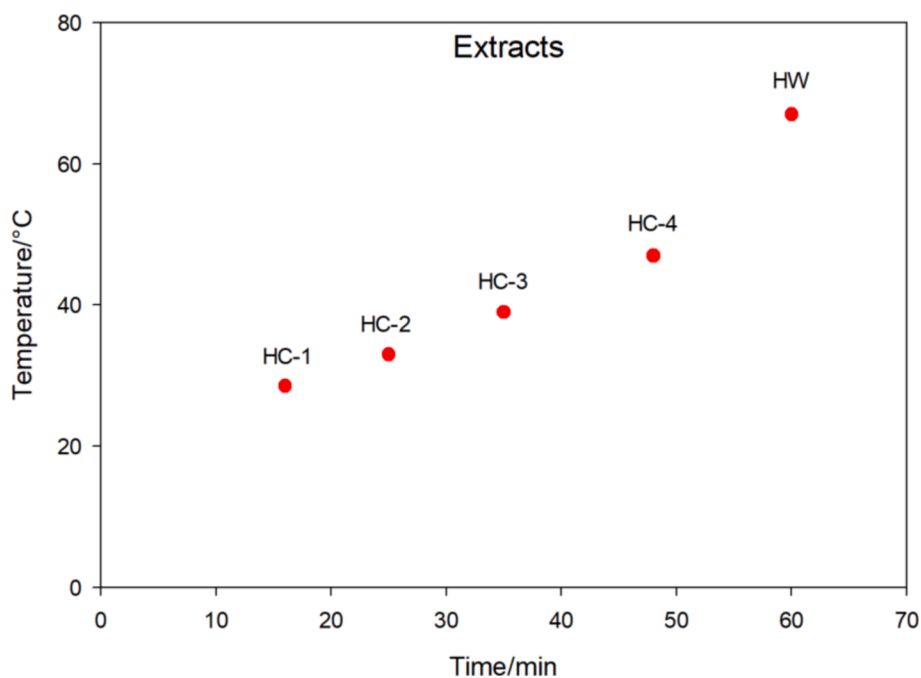

Fig. 1. Time-temperature diagram of the extraction processes. Bark extraction samples: HC = hydrodynamic cavitation extraction, HW = hot-water extraction.

lung fibroblast cells (MRC-5, ATCCCL-171) were used in HCoV-OC43 experiments. A549 cells were cultured in Dulbecco's Modified Eagle Medium (DMEM, Thermo Fisher, Waltham, MA, USA) and MRC-5 cells in Eagle's Minimum Essential Medium (MEM, Gibco, Paisley, UK), both of which were supplemented with 10 % fetal bovine serum (FBS, Gibco, Paisley, UK), 1 % penicillin–streptomycin antibiotics (Gibco, Paisley, UK) and 1 % GlutaMAX (Gibco, Paisley, UK). Both cell lines were maintained at + 37 °C in a humidified incubator with 5 % CO₂. For the experiments, cells were plated on flat-bottomed 96-well microtiter plates (Sarstedt, Numbrecht, Germany) at a density of 12,000 A549 cells or 15,000 MRC-5 cells per well. The cells were then allowed to grow overnight in the incubator.

All bark samples were first dissolved in sterile water to create stock solutions. To test the samples against viruses, concentration series ranging from 10 to 250 µg/mL were prepared by diluting the stock solutions in either DMEM supplemented with 1 % FBS and 1 % GlutaMAX (1 % DMEM, for tests in A549 cells) or MEM supplemented with 2 % FBS and 1 % GlutaMAX (2 % MEM, for tests in MRC-5 cells). The samples were then incubated for one hour with CVA9 (5.48×10^7 pfu/mL) at + 37 °C and 5 % CO₂, or with HCoV-OC43 (1.49×10^4 pfu/mL) at + 34 °C and 5 % CO₂. After incubation, the samples were diluted tenfold in 1 % DMEM or 2 % MEM to prevent cytotoxic effects on the cells. Three technical replicates of the samples were then added on cells along with cell control (plain 1 % DMEM/2% MEM) and virus control (1 % DMEM/2% MEM with virus). In CVA9 experiments, the samples were incubated on the cells overnight at + 37 °C and 5 % CO₂, while in HCoV-OC43 experiments the incubation on cells was carried on for five days at + 34 °C and 5 % CO₂. Final concentration of the samples on cells ranged from 1 to 25 µg/mL and the multiplicity of infection (MOI) was 30 for CVA9 and 0.007 for HCoV-OC43. To test cytotoxicity of the bark extracts on cells, samples without the viruses were also prepared and incubated on the cells similarly.

To follow the infection, we used a cytopathic effect (CPE) assay. After overnight/five-day incubation with the samples, cells were washed twice with PBS and stained for 12 min with crystal violet-containing dye (0.03 % crystal violet, 2 % ethanol and 3 % formalin in H₂O). To remove any excess dye, the cells were then washed twice with sterile water, and finally, lysed with a lysis buffer (47 % ethanol, 12.5 mM HCl, and 19 mM sodium citrate) to create homogenic solution. The absorbance of the samples was measured at 570 nm using Victor™ X4 multi-plate reader (PerkinElmer, Waltham, MA, USA) and normalised against the absorbance of cell control, which was set to 100 %. Data from three technical replicates per sample were plotted as an average bar chart with standard error of means using Graph pad Prism version 6.07 (Dotmatics, San Diego, CA, USA). The experiments were performed twice. Statistical analysis of the CPE results was performed using one-way ANOVA with Bonferroni test. A p-value of 0.05 or less was considered statistically significant.

2.4.3. Antioxidant analyses

Ferric reducing antioxidant power (FRAP) method is based on the capacity of antioxidants to reduce chelated metal ions (Fe³⁺) via single electron transfer (SET) mechanism. In the presence of antioxidants [Fe(III)(TPTZ)₂]³⁺ is reduced and turns to reveal a deep blue color. The methodology is slightly modified from the one reported by Benzie and Strain [24]. Three technical replicates of 25 µL were investigated in a microplate format as previously reported [22]. The samples were added to a reaction mixture containing 20 mM FeCl₃·6H₂O and 10 mM 2,4,6-Tris(2-pyridyl)-s-triazine (TPTZ) in 300 mM acetate buffer (pH 3.6) in transparent flat-bottom 96-well plates. The absorbance was measured at 593 nm with a microplate reader (Varioskan Flash, Thermo Scientific) to monitor the formation of ferrous-tripyridyltriazine complex in dark. A dilution series of FeSO₄·7H₂O was used as a standard compound against which all the results were compared, and sample color effect was minimized with blank subtraction. L(+)-ascorbic acid (150 µM and 800 µM) (VWR Chemicals) was used as a positive control and the results are

expressed as µM Fe(II) equivalents per 1 g of dry extract.

Oxygen radical absorbance capacity (ORAC_{FL}) is based on the ability of antioxidants to prevent peroxy radical from damaging a fluorescent molecule fluorescein. The method used follows the hydrogen atom transfer (HAT) mechanism and has been previously reported [25,26]. Experimental setup has been published [27]. In brief, all the samples were measured in five dilutions and with two technical replicates. Additional dilutions were prepared when needed. The reaction mixture consisted of the sample in 75 mM phosphate buffer (PB) pH 7.5 (Merck) and 0.0816 µM fluorescein as well as 0.153 mM peroxy radical creator 2,2'-azobis(2-methylpropionamide) dihydrochloride (AAPH) in a black opaque flat-bottom 96-well plate. The produced fluorescence (emission 538 nm; excitation 485 nm with bandwidth 12 nm) was monitored with a microplate reader (Varioskan Flash, Thermo Scientific) every 2 min for 21 times. The microplate was kept at 37 °C and briefly shaken prior every measurement. Vitamin E analogue, Trolox ((±)-6-hydroxy-2,5,7,8-tetramethylchromane-2-carboxylic acid) concentrations of 50, 25, 12.5, and 6.25 µM were used as the standard against which all the results were compared. Results are expressed as Trolox equivalents (TE) per gram of dry extract (µM TE/g).

2.4.4. Total phenolics by Folin-Ciocalteu

Extracts were analyzed for their total phenolic content by the Folin-Ciocalteu method [28–30], which is often associated with antioxidant activities. Samples were mixed with Folin-Ciocalteu reagent (Merck KGaA, Darmstadt, Germany) and 20 % Na₂CO₃ (Merck KGaA, Darmstadt, Germany). After 45 min incubation at 40 °C in the dark, the absorbance was measured at 750 nm. The standard curve was prepared using gallic acid (0, 25, 100, 250, and 500 mg/L; stock solution 5 g/L (29.4 mM)). The results are expressed as gallic acid equivalents per gram of dry extract (mg GAE/g).

2.5. Tannin and stilbene analytics

Sorghum tannin was used as a control and its extraction and purification was previously described [31]. In brief, sorghum tannin was extracted from ground grain with methanol containing ascorbic acid and purified by ethyl acetate extraction to remove small phenolics, followed by Sephadex LH-20 chromatography to purify the high-molecular-weight fraction. The freeze-dried powder was stored at – 20 °C.

2.5.1. Acid butanol analysis

To evaluate the condensed tannin contents (CT%) in the samples, a previously published method was used with minor modifications [32]. Samples were dissolved in aqueous acetone (3:7, water: acetone, v/v) at 1 mg/mL. Duplicates of 0–100 µL of each extract in 20 µL increments were reacted with 3 mL acid butanol (5 % concentrated HCl in butanol, v/v) and 100 µL of iron reagent (2 % ferric ammonium sulfate in 2 N aqueous HCl) for 50 min in a 95 °C water bath. After heating, samples were cooled, and absorbances were determined at 550 nm against the acid butanol blank. In addition, the absorbance was scanned at 500–600 nm to establish the λ_{max} and peak symmetry.

2.5.2. Protein precipitable phenolics

To evaluate the protein precipitable phenolics, a previously published method was used with minor modifications [33]. Aliquots of each bark extract sample were dissolved in water at 5 mg/mL, mixed with a pH 5 acetate buffer containing 250 µg bovine serum albumin, incubated at room temperature for 30 min, centrifuged for 5 min at 13,000 rpm, and the supernatants aspirated. The remaining precipitates were redissolved in the sodium lauryl sulfate/triethanolamine reagent, vortexed, and mixed with ferric ammonium sulfate solution before determining absorbance at 510 nm.

2.5.3. Thiolysis–HPLC–DAD

Purified proanthocyanidins were analyzed by thiolysis, according to

a previously published methodology [31,32]. In brief, samples were dissolved in HCl-MeOH-thiol solution (32 % (v/v) HCl in methanol; 5 % (v/v) toluene- α -thiol in methanol) at 5 mg/mL and incubated at 40 °C for 30 min. Samples were briefly cooled in a freezer and filtered with 0.22 μ m cellulose acetate spin-filters (Spin-X, Costar 8161, Corning Incorporated, Salt Lake City, UT, USA). The thiolytic degradation products were analyzed by HPLC using an Agilent 1100 HPLC with diode array detection and controlled by ChemStation Rev. A.09.03 software. The column was a Thermofisher Hypersil Gold C8 (150 \times 4.6 mm, 3 μ m). Sample injection volume was 10 μ L. The gradient program employed 0.13 % (v/v) trifluoroacetic acid (TFA) in nanopure water (A) and 0.10 % (v/v) TFA in acetonitrile (B) at a flow rate of 0.5 mL/min at 27.0 °C for a duration of 48 min, as follows: 0–3 min, isocratic at 15 % B; 3–8 min, increase to 20 % B; 8–10 min, increase to 30 % B and hold isocratic until 28 min; 28–32 min, increase to 70 % B; 37–40 min, decrease to 15 % B, and re-equilibrate. Reaction products were detected at 220 nm and were identified by their retention times and spectral characteristics compared to two well characterized condensed tannin samples, from Sorghum grain and from *Neptunia lutea* [34]. Products were quantitated based on peak areas and converted to moles of extender and terminal units. The chromatograms from control samples that did not contain acid or thiol and were not heated were used to confirm that the proanthocyanidin did not contain any flavan-3-ol monomer contamination that would interfere with terminal unit determination.

2.5.4. Acid methanol degradation to yield anthocyanidins

A previously published method for acid methanol degradation of condensed tannins with HPLC-DAD detection of the anthocyanidins was used with minor modifications [31]. Approximately 1 mg of each bark extract was dissolved in 200 μ L methanol (control) or 1 M HCl in methanol (sample), mixed, and incubated at 70 °C for 2 h. The samples and controls without HCl were diluted with 200 μ L MeOH before filtering with 0.22 μ m cellulose acetate spin filters and injecting 10 μ L on the same HPLC system as described above. The gradient utilized 0.13 % (v/v) trifluoroacetic acid in water (A) and 0.10 % (v/v) TFA in acetonitrile (B) at a flow rate of 0.5 mL/min at 27 °C for a duration of 37 min, as follows: 0–30 min, increase 15 % B to 30 % B; 30–32 min, decrease to 15 % B; 32–37 min, hold isocratic and re-equilibration. Reaction products were detected at 220 nm and 500 nm and were identified by their retention times and spectral characteristics, as compared to authentic standards.

2.5.5. Stilbene monomer and dimer analysis with UPLC-MS

For stilbene analysis, the dried extracts (10.25 \pm 0.25 mg) were dissolved to a 10 mL of water in a planar shaker at RT for 60 min (300 rpm) and filtered through a 0.2 μ m PTFE filter prior analysis. The samples were made in triplicate. A four-point standard curve was prepared from piceatannol (ChemFaces, Wuhan, China) by dissolving to 10 % (v/v) MeOH in water. Concentration of the piceatannol standard ranged from 0.02 to 100 μ g/mL. The stilbene analysis was carried out with a LC-MS using a previously published method with minor modifications [35]. In brief, an Acquity UPLC (Waters Corp.) containing a binary solvent manager and a diode array detector was coupled to a quadrupole-Orbitrap mass spectrometer (QExactiveTM, Thermo Scientific GmbH). Chromatographic separation of stilbenes was achieved with an Acquity BEH phenyl column (2.1 \times 100 mm, 1.7 μ m, Waters Corp.). The mobile phase consisted of acetonitrile (A) and 0.1 % (v/v) HCOOH in water, and the elution profile was: 0–0.5 min, 0.1 % A in B; 0.5–5 min, 0.1–30 % A in B; 5–7 min, 30–40 % A in B; 7–7.1 min, 40–90 % A in B. Flow rate was 0.5 mL/min and injection volume 5 μ L. The mass spectrometer contained a heated ESI source and was operated in negative ion mode. Spray voltage was set at –3.0 kV and capillary temperature 380 °C. The in-source collision-induced dissociation was set to 30 eV and full scan mass range was m/z 150–2250. Data was processed with Thermo Xcalibur Qual Browser software. For quantitation, peak areas

were integrated from the extracted ion chromatograms obtained from the total ion chromatograms using the m/z values of the most intensive ions of each stilbene components, i.e., aglycone ions for monomeric stilbene glycosides and molecular ions for dimeric stilbene glycosides.

2.6. Elemental, carbohydrate, and terpene analytics

2.6.1. Elemental analysis

Elemental analysis for extracts was carried out using a closed wet HNO₃-H₂O₂ digestion method [36] in a microwave oven (CEM MDS 2000) and the extract was analyzed by an iCAP 6500 DUO inductively coupled plasma (ICP)-emission spectrometer (Thermo Fisher Scientific, Cambridge, UK).

2.6.2. Carbohydrate analysis by methanolysis

The extract carbohydrates were analyzed with acid methanolysis [37] using previously reported methods [14]. Briefly, sample extracts in duplicates were depolymerized by acid methanolysis at 105 °C for 3 h. Samples were silylated and analyzed with gas chromatography using a flame ionization detector (GC-FID, Shimadzu GC-2010, Kyoto, Japan). Method analyzes glucose (Glu), mannose (Man), galactose (Gal), xylose (Xyl), arabinose (Ara), glucuronic acid (GlcA), galactouronic acid (GalA), rhamnose (Rha) and 4-O-methyl-glucuronic acid (MeGlcA) in the samples. Monomeric sugars in the extracts were analyzed using the same GC-FID system without prior acid methanolysis [6].

2.6.3. Terpene and terpenoid analysis

For the terpene and terpenoid analyses, i.e., mono-, sesqui- and diterpenes, aliquots of the original extracts were extracted with dichloromethane supplemented with 1-chlorodecane (25 μ g/mL) as an internal standard, and the mixture was mixed vigorously by vortexing. All the extracts were analyzed in duplicates. After this, the samples were centrifuged (3,000 rpm, 10 min, 21 °C) to collect all material into the solvent, and incubated for 15 min in an ultrasonic bath at 20 °C. The vortexing and centrifugation steps were repeated, and the samples reincubated for 15 min in the ultrasonic bath. The samples were mixed by vortexing and centrifuged. One mL out of the dichloromethane phase was pipetted into the gas chromatography (GC) vial. Terpene and terpenoid compositions were analyzed with a GC-MS instrument (Agilent 7980B) equipped with a ZB-5MSplus column (30 m \times 0.25 mm, film thickness 0.25 μ m). Humulene (10 and 20 μ g/mL) was used as an external standard. The protocol for the column oven was as follows: starting temperature 30 °C, hold time 0 min, temperature increase rate 10 °C/min, end-temperature 230 °C, hold time 5 min, temperature increase rate 40 °C/min, hold time 2 min. The injector temperature was 230 °C. Helium with the flow rate of 1.2 mL/min was used as a carrier gas. The GC instrument equipped with a mass selective detector (Agilent MSD 5977A) was heated at 230 °C. The sample volume was 1 μ L (splitless injection into the column). The results were calculated per volume of the extract (mg/L).

2.7. Technical feasibility analysis

The technical feasibility analysis was carried out based on the idea of upscaling the HC and HW extraction methods to an industrial scale. An industrial process for isolating and drying of the bark extract was presented, and material and energy balances for the HC and HW processes were constructed. Optimizing the extraction process would require carrying out process simulation experiments and performing detailed analysis of the results; however, this was not in the scope of this work. Instead, the objective was to pinpoint the process steps, which should be improved for increasing the overall feasibility. The analysis was limited to investigating the material and energy balances of the designed processes because making detailed economic assessment was seen premature: for most of the process steps no experimental data were available. To help the reader to grasp the details of the calculations, detailed

information about the sources for the variables is presented in the Results and Discussion section, the general description is, however, given herein below and supported by Fig. 2.

The raw material for the process is spruce bark, which is first mechanically pretreated to decrease the particle size through shredding (in the case of HW) or milling (performed twice in the case of HC). Thereafter, water is added, the amount depending on the extraction method based on the specific experiments performed and discussed in this study, and HC or HW treatment is carried out. The insoluble bark residue is then separated from the extract with decanter centrifuge. The bark residue is directed to a mechanical pressing stage, where the extract contained in the bark residue is separated. Thereafter, the bark residue is dried in a drum drier. The extracts from decanter centrifuging and mechanical pressing are combined and centrifuged to separate the solid material remaining in the aqueous extract after the separation stages. From centrifuging, the separated solids are directed to drum drying and the liquid extract is evaporated under vacuum. The last drying stage for the extract is spray drying, after which the powdered extract components are collected. The capacities of the processing units are not discussed in this work, but it is simply assumed that the equipment sizes and equipment unit numbers are such that the process can be run smoothly. Moreover, the pumps, conveyer belts and screws or other required equipment are not considered in this technical feasibility analysis. The estimations for the capital expenditures or operational costs (CAPEX and OPEX) of the process lines were also beyond the scope of this paper. The technical details assumed for the extraction processes and utilized in the calculations are presented in Table 2.

2.7.1. Material balance

The starting point for the material balance calculation was the properties of the raw material, i.e., spruce bark from the above-mentioned sawmill (SCA Wood in Rundvig, Sweden). In the calculations, the determined DMC (46.3 wt%) of the spruce bark was used. The annual amount of the raw material was set to 14,000 oven dry tons (ODT), corresponding to the estimated annual amount of the spruce bark side-stream at the sawmill [38,39].

The total dissolved solids (TDS) amounts in the extracts after the HC and HW treatments were estimated based on the controlled drying of the

Table 2

Technical properties of the extraction processes utilized in the technical feasibility analysis calculations; ODT = oven dry ton; t/a = annual tons; DMC = dry matter content; HC = hydrodynamic cavitation extraction; HW = hot-water extraction. Liquid to solid ratio is expressed in solid dry basis.

Property	Amount	Unit
Amount of spruce bark (ODT)	14,000	t/a
Bark DMC	1,667	kg/h
Fresh bark amount	46.3	wt. %
	30,251	t/a
	3,601	kg/h
Conditions in HC		
- liquid:solids (w:w)	22.8	–
- T	(20 to)33	°C
- t	25	min
Conditions in HW		
- liquid:solids (w:w)	8.6	–
- T	67	°C
- t	60	min
Days of operation	350	d/a
Hours of operation	8,400	h/a

extracts at 105 °C. In addition, the experimentally determined terpene amounts were added to the TDS, as it was assumed that these compounds evaporate during the drying. For HC, the values after 25 min treatment were used (labelled HC-2). The amount of the other individual components was based on the experimental results presented in this paper (freeze-dried samples for the tannins). The TDS and the concentrations of the individual components were assumed to stay unchanged in the process steps, apart from monoterpene concentration, which was assumed to decrease during vacuum evaporation.

When experimental data were not available, the dry matter contents (DMC) of the different streams in the designed process were based mostly on literature data or other reliable sources (e.g., equipment manufacturers' data). Bark material losses were assumed during mechanical shredding and milling prior to insertion into the HW and HC steps (details provided in Results and Discussion).

2.7.2. Energy balance

Experimental data was used to estimate the energy consumption

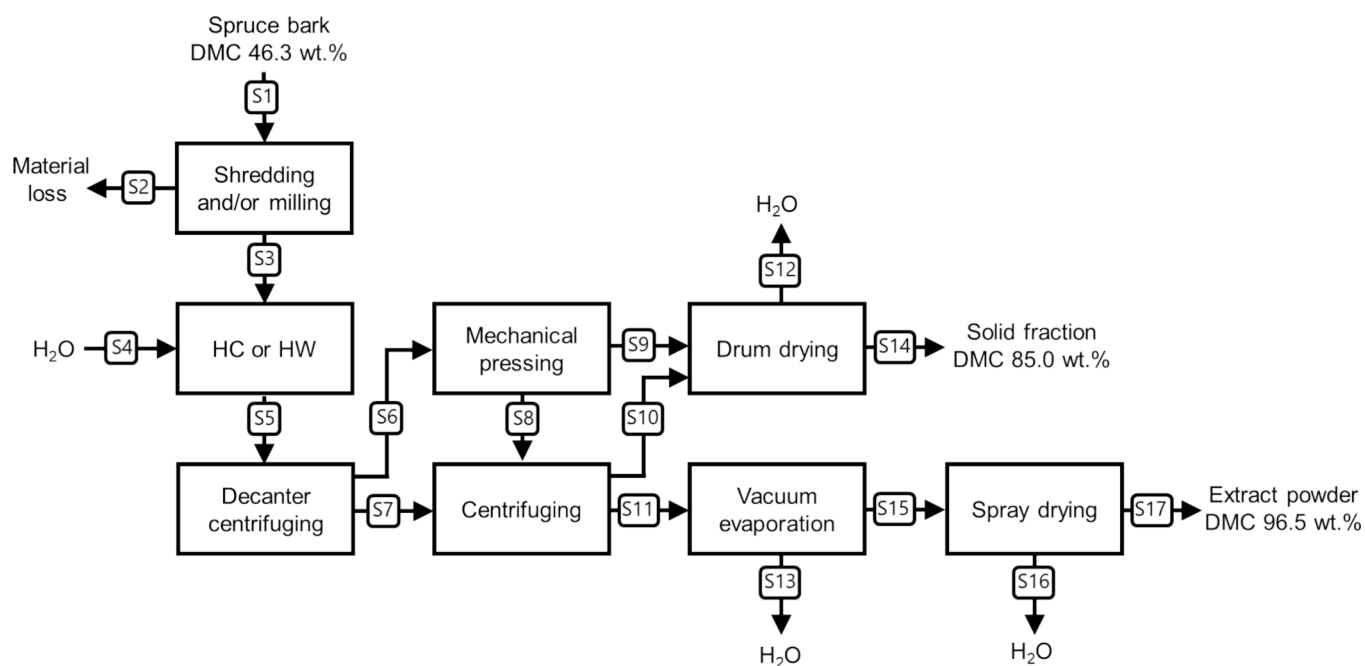

Fig. 2. Process scheme for isolating and drying the extracted components from bark. Different streams in the process are numbered and the streams are referred to according to these symbols (S1-S17). HC = hydrodynamic cavitation; HW = hot-water extraction; DMC = dry matter content.

during the mechanical pretreatment of the bark (shredding or milling). Also, estimating the energy required for the HC and HW steps was based on the experiments. Otherwise, the energy balance was constructed based on data from literature or other reliable sources (e.g., equipment manufacturers). In the balance, the gross energy requirement for the separate process steps is estimated and the total energy requirement is simply the sum of the individual steps. In the balance, it is not specified, which part of the energy originates from steam and which from electricity.

3. Results and discussion

3.1. Extraction yield

The obtained total dissolved solids (TDS) results for the extracts are expressed in Table 3. The hot-water extracted product yielded approximately 3.5-fold higher TDS than extracts obtained with hydrodynamic cavitation. The reason for the large difference in the TDS content resulted from the different solid to water ratios, which was about 2.7 times lower for HC compared to HW. However, when normalized to unit original dry biomass, HW delivered approximately 30 % higher TDS than HC, showing higher extraction yield. It is worth noting that in the HC extraction process, the peak extraction was achieved already at the end of biomass insertion, just after 16 min of process time at 28.5 °C. The difference of the total solids (TS) content was due to the usage of solid separation by meshes for the HW extraction, whereas no prior separation was used for the HC extraction. All the extracts were further handled and dried alike as described in section 2.3. In the Table 3 also the yield of the extraction stage is presented, calculated as the unit mass of TDS obtained per unit energy consumption. As it was expected based on the energy figures shown in Table 1, HC affords higher yield of the extraction process yield, peaking at the first sample (HC-1) with a HC to HW extraction stage yield ratio greater than 7.

3.2. Antioxidant activities and total phenolic content

Two methods with distinct mechanisms were used to investigate the antioxidant capacity: FRAP and ORAC. The antioxidant activities and total phenolic content of the freeze-dried (FD) and spray-dried (SD) extracts are shown in Fig. 3. All the extracts were highly active in the antioxidant tests as also witnessed in previous studies of spruce bark [40,41]. In FRAP test, which measures the ferric reducing capacity of the sample, hot-water extract indicated higher activity than the extracts obtained with hydrodynamic cavitation with significant difference. Similar trend is visible in ORAC, measuring peroxy radical absorbance, while the difference was only significant with spray-dried samples. Total phenolic content measured by the Folin-Ciocalteu method is similar for all the extracts with only minor significant differences.

Table 3

The total dissolved solids (TDS) and total solids (TS) for the extracts of this study. TDS is shown for unit volume of the extract (g/L) and for unit original dry biomass (mg/g) assuming that all the water was extracted. The extraction stage yield was calculated as the unit mass of TDS obtained per unit energy consumption. HC = hydrodynamic cavitation; HW = hot-water extraction.

Sample	TDS (g/L)	TDS (mg/g)	TS (g/L)	Extraction stage yield (kg TDS/kWh)
HC-1	6.95	158.2	124.6	0.581
HC-2	7.00	159.4	128.9	0.376
HC-3	6.82	155.3	125.0	0.261
HC-4	7.06	160.7	95.5	0.195
HW	24.60	212.1	0.0	0.079

3.3. Antimicrobial activities

3.3.1. Antibacterial assessment

To examine the effect of the extracts against bacteria, two recombinant constitutive light emitting indicator strains were used. *Escherichia coli* is the most common gram-negative bacterium causing both clinical and epidemiological challenges and *Staphylococcus aureus* is the predominant gram-positive strain causing hospital acquired infections [42]. All the spray-dried and lyophilized extracts showed significant antibacterial activities against both indicator strains *E. coli* and *S. aureus* at the content of 1 mg/mL (Fig. 4). The dose-responses of the all concentrations can be found in Supplementary Figure S1. However, hot-water extract exhibited lower activities than hydrodynamic cavitation extracts. The trend is therefore opposite to the one indicated in the antioxidant tests. The gram-positive *S. aureus* strain was more sensitive to the extracts, which aligns with previous studies, where it has been hypothesized to be caused by the absence of the protective lipopolysaccharide layer present in the gram-negative species [43].

3.3.2. Antiviral assays

To examine whether the bark extracts have antiviral effects against CVA9 and HCoV-OC43, a CPE assay was carried out. Both viruses were pre-treated with freeze-dried and spray-dried bark samples at different concentrations before adding the sample-virus solutions on cells. In addition, a corresponding amount of samples without the viruses were also added on cells to assess the cytotoxicity of the bark extracts on A549 cells and MRC-5 cells. The CPE assay results show that the freeze-dried and spray-dried bark extracts have dose-dependent antiviral effects against CVA9 (Fig. 5) and HCoV-OC43 (Fig. 6). CVA9 lost some of its infectivity when pre-incubated with the highest tested sample concentration (250 µg/mL) of the bark extracts. The viability of cells treated with these samples increased to approximately 65–80 %. HCoV-OC43 infectivity, on the other hand, was mostly lost when the virus was pre-incubated with 250 µg/mL bark extracts, and the cell viability increased close to cell control level with all the samples. Importantly, none of the bark extracts showed apparent cytotoxicity on A549 cells or MRC-5 cells, even at the highest tested concentration. This verified that the antiviral results observed with bark extracts were reliable and not masked by possible direct effect of bark extracts on cells.

3.4. Chemical composition

3.4.1. Condensed tannin content

As bark is known to contain condensed tannins with potentially beneficial properties, we were interested in seeing if the different extraction and handling processes would extract different types or amounts of tannin. To better understand the bark tannins, they were compared to a well-characterized condensed tannin from *Sorghum* grain [31]. The condensed tannin composition of extracts is established from the color yield in the acid butanol assay. We found that the highly purified Sorghum tannin comprised of 100 % CT (Table 4). In contrast, the bark preparations were generally less than 20 % condensed tannin, with the maximum content detected in freeze-dried HW (25.1 %) (Table 4). It has previously been found that temperature plays a large role in the extraction of tannins [44] and therefore, our finding of higher content in HW extracts is not surprising. However, Kemppainen et al. [44] used quebracho tannin as a standard in the acid butanol assay, which differs largely from the structure of the used Sorghum tannin as well as the analyzed spruce bark tannins and the results are not as such directly comparable.

The test for protein precipitable phenolics revealed that only about 40 % of the added polyphenolics were precipitated for all the samples, while for the Sorghum tannin 85 % of the added polyphenols were precipitable. The difference is likely caused by the chain length of the condensed tannins. The chain length of the HC and HW bark tannins was much shorter than the chain length of the Sorghum tannin (Table 4). In

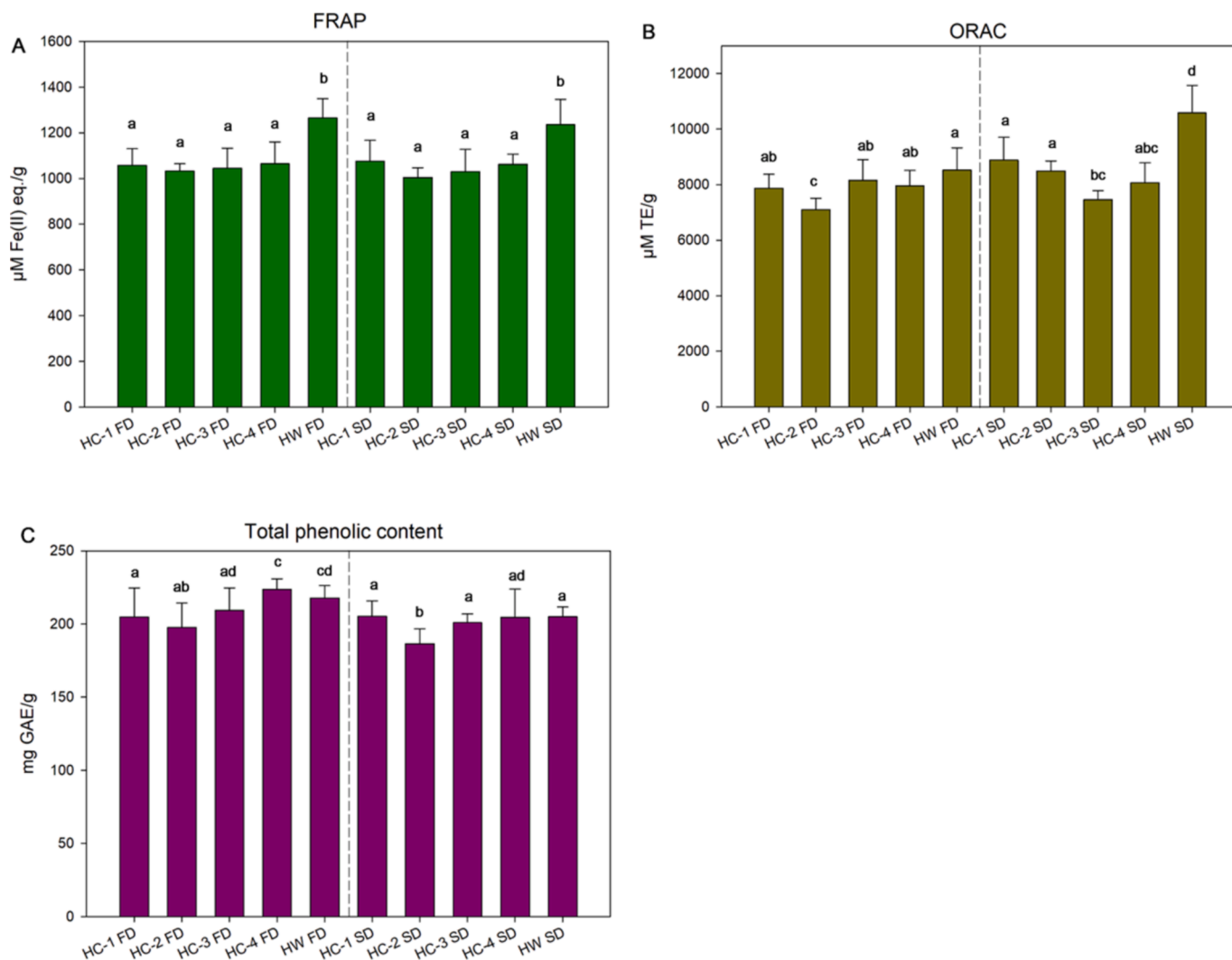

Fig. 3. Antioxidant activities of extracts measured in FRAP (A) and ORAC (B) and total phenolic content (C). Error bars represent standard deviation of the replicates (n = 3–18). Different letters above the columns show significant differences at the 95 % confidence level (p < 0.05). HC = hydrodynamic cavitation extraction, HW = hot-water extraction, FD = freeze-dried and SD = spray-dried samples.

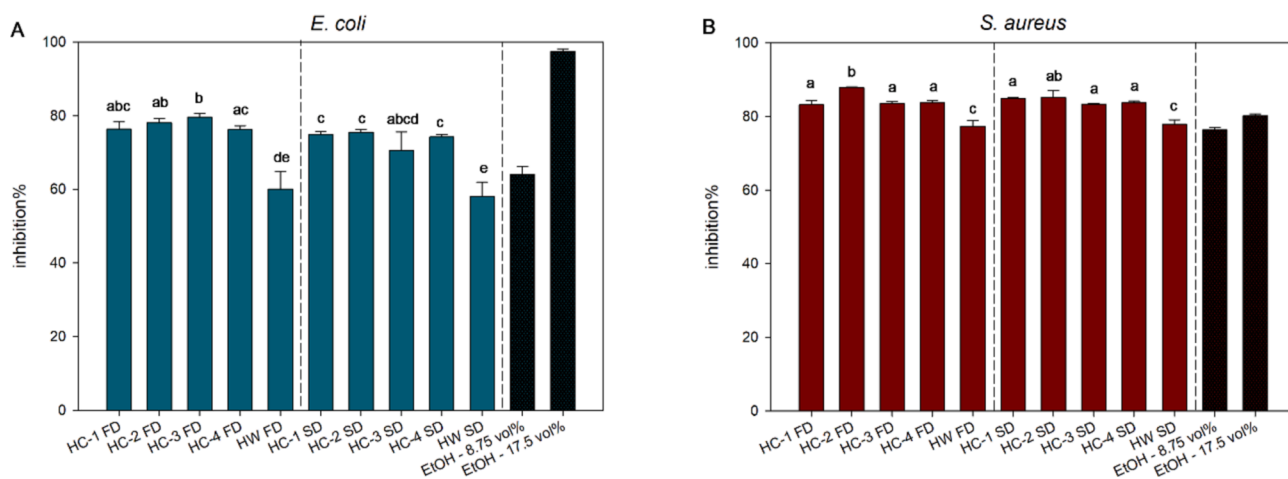

Fig. 4. Antibacterial inhibition of 1 mg/mL content against *E. coli* (A) and *S. aureus* (B). Error bars represent the standard deviation between sample triplicates. Different letters above the columns show significant differences at the 95 % confidence level (P < 0.05). Ethanol (EtOH) was used as a positive control in the experiments. The responses of all concentrations can be found in Supplementary Figure S1. HC = hydrodynamic cavitation extraction, HW = hot-water extraction, FD = freeze-dried, and SD = spray-dried samples.

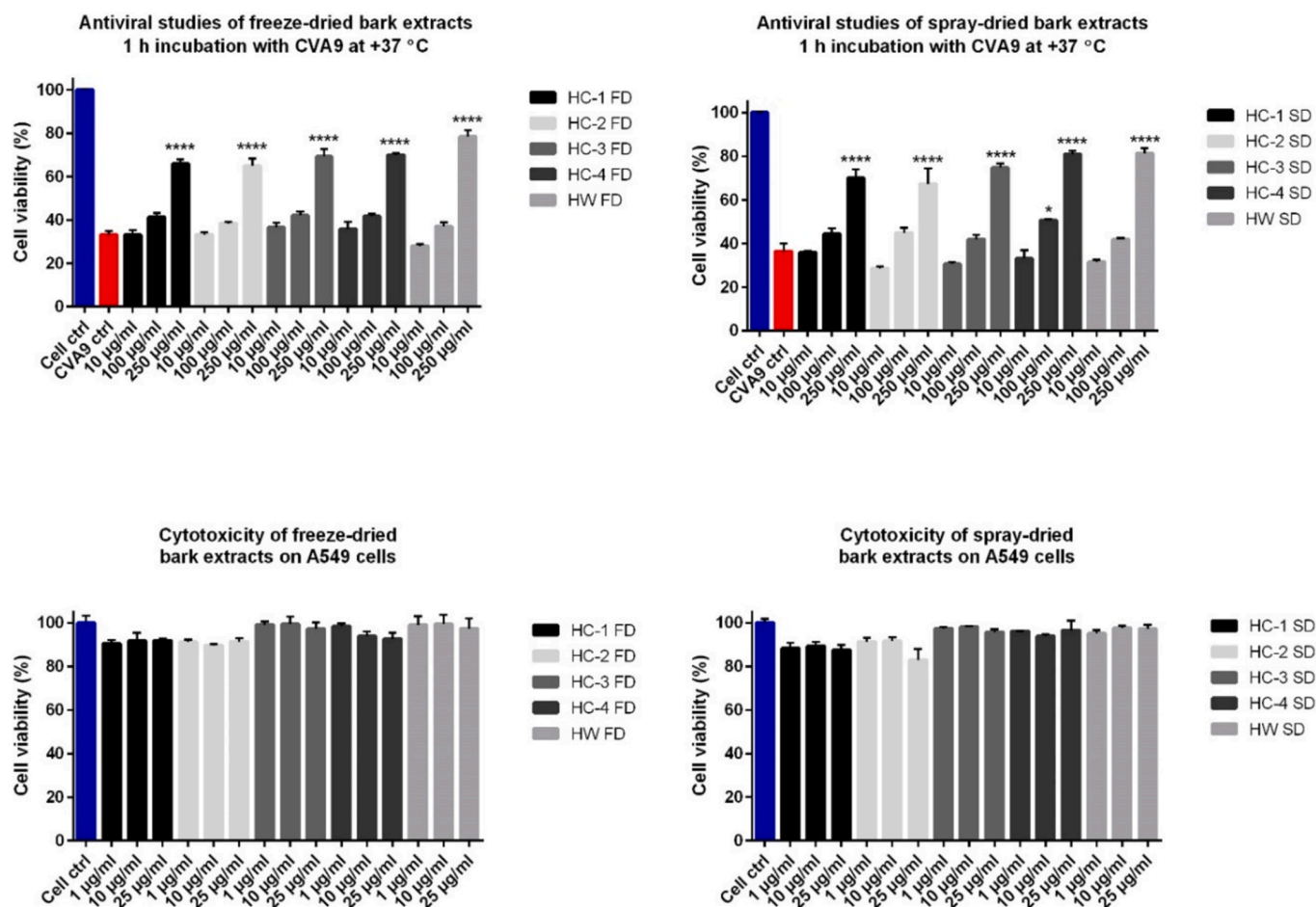

Fig. 5. Activities of freeze-dried (FD) and spray-dried (SD) bark extracts on coxsackievirus A9 (CVA9) and the cytotoxicity of the samples. The viabilities are presented as mean \pm SEM of three technical replicates. Statistically significant differences between antiviral samples and CVA9 control were analysed using one-way ANOVA with Bonferroni test. The differences are indicated with asterisks: * $p < 0.05$, *** $p < 0.0001$. HC = hydrodynamic cavitation extraction, HW = hot-water extraction.

general, longer chain length allows the tannin to form more contacts and cross links with the protein leading to more precipitation [45].

As a degradative method, thiolysis offered more information about the CT structure in the extracts (Table 4 and Supplementary Table S2). The well characterized tannin from *Neptunia* was used in addition to Sorghum tannin to identify peaks in the chromatograms. The analysis reveals hydroxylation patterns (procyanidin, PC vs. prodelphinidin, PD), esterification with galloyl groups, and chain length (mDP). The highest prodelphinidin (PD) ratio (9 %) was obtained with the lyophilized HC-3 extract, while it seemed that generally the spray-dried fractions showed higher ratio of procyanidin (PC). However, the differences between the extracts seemed small and proportion of PC was from 91 to 97.2 %, suggesting the spruce tannin is more similar to the Sorghum tannin and not to the structurally more complex *Neptunia* tannin. The mean degree of polymerization (mDP) revealed that the chain length of the tannins seemed to be highest in the spray-dried products. However, the tannin was relatively short chain length compared to the Sorghum and *Neptunia lutea* control samples. Short chain condensed tannins appear to be typical for spruce bark extracts [6,40,46].

The anthocyanidin percentages were identified by acid methanol degradation. Acid methanolysis breaks the interflavan bond and any ester bonds to produce cyanidin from catechin, epicatechin, and (epi)catechin gallate extender units; delphinidin is generated from (epi)gallocatechin and (epi)gallocatechin gallate; pelargonidin is produced from afzelechin/epiafzelechin. Delphinidin, cyanidin, and pelargonidin were identified with commercial standards (Table 5). Pelargonidin conjugate

and hydroxycinnamic acid derivative were identified by spectral similarities, and several peaks were left unidentified. It seems that the drying method influences the anthocyanidins released from the parent condensed tannin. Some of the unidentified products can only be found in the spray-dried samples: UN1, UN3 and UN4. Spray-drying also yields higher contents of hydroxycinnamic acid derivatives whereas freeze-drying seems to increase the amount of pelargonidin conjugates. Condensed tannins are considered antibacterial e.g., for their ability of denaturing proteins in bacterial cell membranes [47]. Similarly, also tannin-rich spruce bark extracts have previously been established antimicrobial against both bacteria and viruses [48]. Polyphenols in general are usually known for their antioxidant properties *in vitro*, due to their hydrogen atom donation and single-electron transfer [49–51]. The elevated condensed tannin content of HW extracts likely contributes to the witnessed slightly higher antioxidant and antiviral activity than obtained with HC extracts in this study.

3.4.2. Stilbene monomers and dimers

Since bark extracts are known to contain stilbene structures with various bioactivities, we were interested in investigating whether these differed across the extracts. Stilbene monomers and dimers were investigated using LC-MS. Fig. 7 shows that the highest stilbene yield was obtained in hot-water extracted samples and lyophilized extracts delivered consistently slightly higher concentrations of stilbenes. A hypothesis, partially supported by previous evidence with ultrasonic-assisted extraction of plant material also containing cavitation

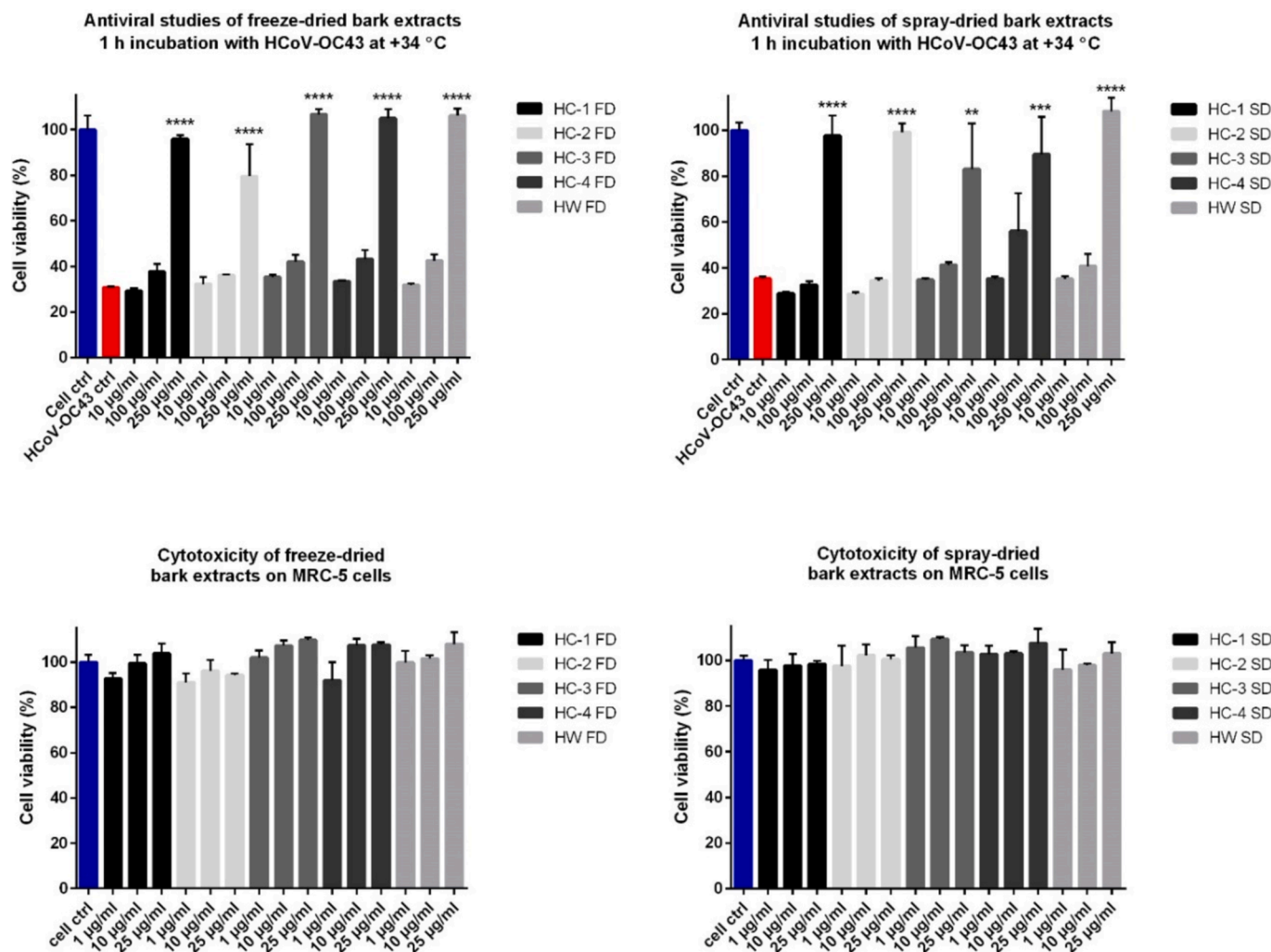

Fig. 6. Activities of freeze-dried (FD) and spray-dried (SD) bark extracts on seasonal human coronavirus OC43 (HCoV-OC43) and the cytotoxicity of the samples. The viabilities are presented as mean ± SEM of three technical replicates. Statistically significant differences between antiviral samples and HCoV-OC43 control were analysed using one-way ANOVA with Bonferroni test. The differences are indicated with asterisks: **p < 0.01, ***p < 0.001, ****p < 0.0001. HC = hydrodynamic cavitation extraction, HW = hot-water extraction.

Table 4

Structural information of the condensed tannin composition obtained by tyolysis and the overall condensed tannin content (CT%) obtained by the acid butanol assay. PC = procyanidin; PD = prodelphinidin; mDP = mean degree of polymerization; CT = condensed tannins; HC = hydrodynamic cavitation; HW = hot-water extraction.

Sample	PC/PD ratio	%galloyl	mDP	CT%	
Sorghum PC	100/0	0	16	100	
<i>Neptunia lutea</i>	12.0/88.0	32.0	11.5	100	
Freeze-dried	HC-1	95.1/4.9	8.7	4.0	11.5
	HC-2	96.2/3.8	4.9	4.0	19.4
	HC-3	91.0/9.0	7.5	7.6	17.3
	HC-4	95.4/4.6	4.8	6.6	13.1
	HW	96.1/3.9	4.0	5.3	25.1
Spray-dried	HC-1	93.4/6.6	7.3	6.2	13.6
	HC-2	97.1/2.9	5.4	6.4	14.7
	HC-3	96.5/3.5	7.6	9.5	13.6
	HC-4	94.5/5.5	5.2	5.0	13.6
	HW	97.2/2.8	5.0	8.6	17.3

processes [52] is that prolonged hydrodynamic cavitation with increasing temperature destroyed the structure of stilbenes, thereby resulting in the progressive decrease of their concentration in the extracts.

The identified monomeric stilbene glycosides are shown in Fig. 8. The three primary glycosides in spruce bark, isorhapontin, astringin and piceid, were accompanied with piceatannol hexoside. Isorhapontin was the most abundant stilbene monomer, which is in accordance with previous studies, while our findings show significant reduction in the concentration of astringin [53,54]. The concentration of astringin has been previously shown to be highly influenced by the UV light exposure [54]. However, as all the raw material was handled similarly, this has no effect on the comparison of the extracts.

The content and identity of stilbene dimers is presented in Fig. 9. All the dimeric stilbenes identified composed of piceatannol and/or isorhapontigenin hexosides as monomers. While stilbene dimers have been previously identified in spruce stem bark [53,54], most of publications are limited on stilbene monomer analysis. Alike condensed tannins, also stilbenes are synthesized by the plants as a response to stress and microbial infections and are therefore known for their antioxidant and antibacterial properties [5,55]. In a review by Metsämuuronen and Siren [47], it was summarized that flavonoid aglycones are usually reported more active against micro-organisms than the phenolic glycosides. Here, stilbene glycosides were predominantly characterized. If the trend for stilbenes is like for flavonoids, this could offer explanation, why stilbene-rich hot-water extracts seemed to exhibit slightly higher antioxidant and antiviral activities, but only moderate antibacterial efficacy

Table 5

Anthocyanidin percentages (%) detected in the hydrodynamic cavitation (HC) and hot-water (HW) extracts by acid methanol degradation. nd = not detected, Del = delphinidin, Cya = cyanidin, Pel = pelargonidin, Un = unknown, HCA = hydroxycinnamic acid.

		Del	Cya	Pel. conj.	Pel	Un1	Un2	HCA der.	Un3	Un4
Retention time (min)		10.8	15.3	18	20.4	25.3	25.7	26.5	30.8	31.3
Freeze-dried	HC-1	nd	71.5	18.3	6.8	nd	3.3	nd	nd	nd
	HC-2	nd	64.8	11.8	12.6	nd	5.7	5.1	nd	nd
	HC-3	nd	66.6	16.0	12.2	nd	5.2	nd	nd	nd
	HC-4	nd	63.9	15.1	12.5	nd	4.9	3.5	nd	nd
	HW	nd	69.7	13.0	9.6	nd	4.1	3.7	nd	nd
Spray-dried	HC-1	nd	54.3	7.8	15.6	nd	9.7	6.5	3.1	2.9
	HC-2	nd	62.0	9.5	13.6	nd	6.8	5.9	nd	2.1
	HC-3	nd	58.7	8.6	14.8	nd	7.8	6.9	3.3	nd
	HC-4	nd	61.7	8.5	13.8	nd	7.6	3.5	2.2	2.8
	HW	nd	62.5	7.8	12.2	2.6	6.0	4.1	2.3	2.4

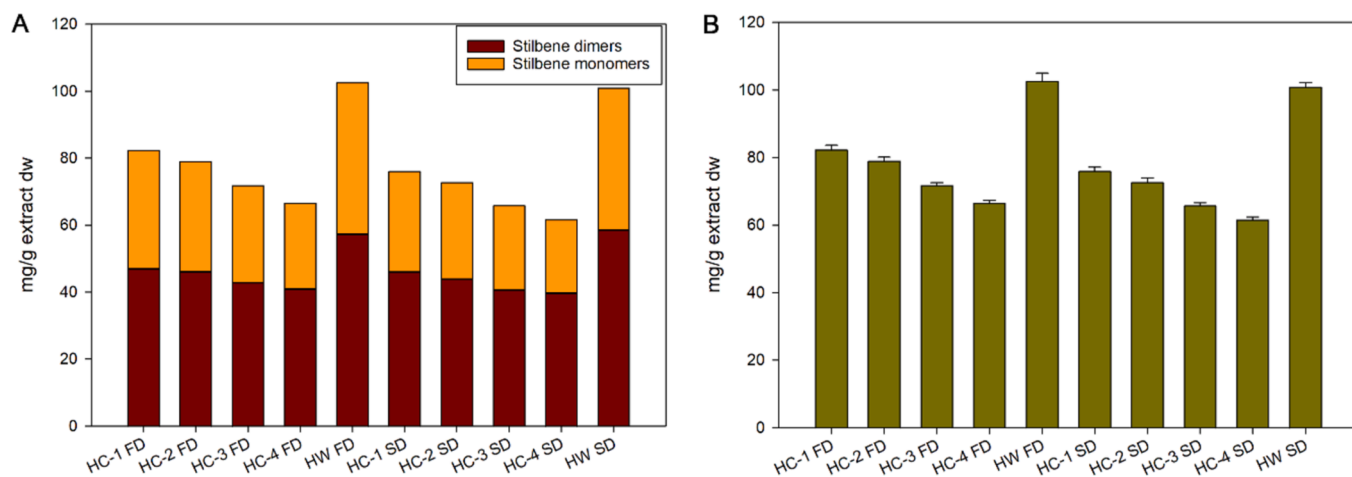

Fig. 7. Content of stilbene monomers and dimers (A) and overall stilbene content with standard deviation (B) in mg/g extract dry weight (n = 3). HC = hydrodynamic cavitation extraction, HW = hot-water extraction, FD = freeze-dried and SD = spray-dried samples.

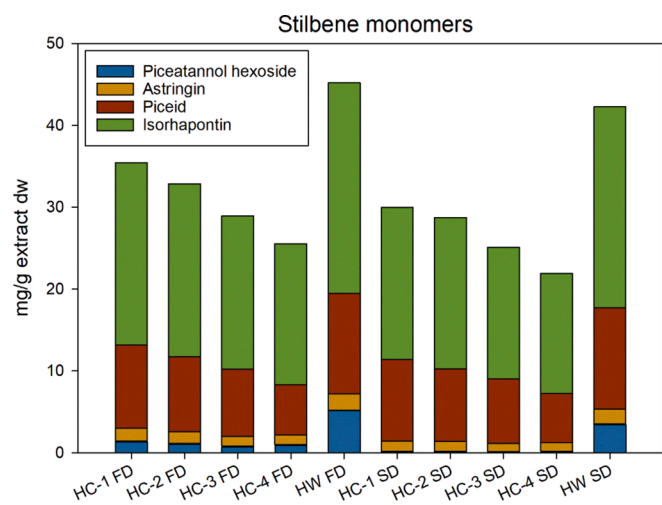

Fig. 8. Content of monomeric stilbene glycosides in mg/g extract dry weight. HC = hydrodynamic cavitation extraction, HW = hot-water extraction, FD = freeze-dried and SD = spray-dried samples.

compared to extracts from hydrodynamic cavitation of this study.

3.4.3. Mono-, oligo- and polysaccharides

During tannin analysis, it was evident that the extracts comprise high amounts of non-tannin components in contrast to the Sorghum standard that was 100 % condensed tannin. A large amount of the non-tannin

material was preliminarily identified as carbohydrates. Therefore, we were interested in seeing, if the saccharide profile would differ between the extracts and different drying methods. The monosaccharide and oligo- and polysaccharide components are shown in Table 6.

The total carbohydrate concentration profile shown in Fig. 10 seemed to be quite similar for all the extracts. However, it was evident that HW extraction showed lower monosaccharide and higher oligo- and polysaccharide content than HC extracts.

It was found that the carbohydrate content was high in all the extracts, accounting for more than half of their mass. This is not surprising as no purification was applied to the extraction products. Monosaccharide concentrations revealed that the extracts contained mostly fructose and glucose, while the HW extract contents were slightly lower. HC extracts contained slightly more glucose (70.3–83.8 mg/g) than HW extracts (58.8–60.6 mg/g). In case of fructose, similar differences can be observed 164.2–164.8 mg/g for HW extracts and slightly higher values (169.9–187.7 mg/g) for HC extracts. Overall, glucose and fructose comprised 92–95 % of the monosaccharide content.

Differences were also observed in the oligo- and polysaccharide content of HW and HC extracts. HW extracts had higher amounts of glucans compared to HC extracts, which was opposed to glucose contents in monosaccharide analysis, indicating that hydrodynamic cavitation releases more glucose from glucans than hot-water extraction. Extracts contained galactouronic acid, rhamnose, galactose, arabinose and xylose that constitute the spruce bark pectin [56]. Carbohydrates provide nutrition for the micro-organisms, and it seems that the higher the total carbohydrate concentration (mono- and oligo and polysaccharides) the lower the witnessed antibacterial activity. To decrease the carbohydrate concentration and enrich beneficial polyphenolic

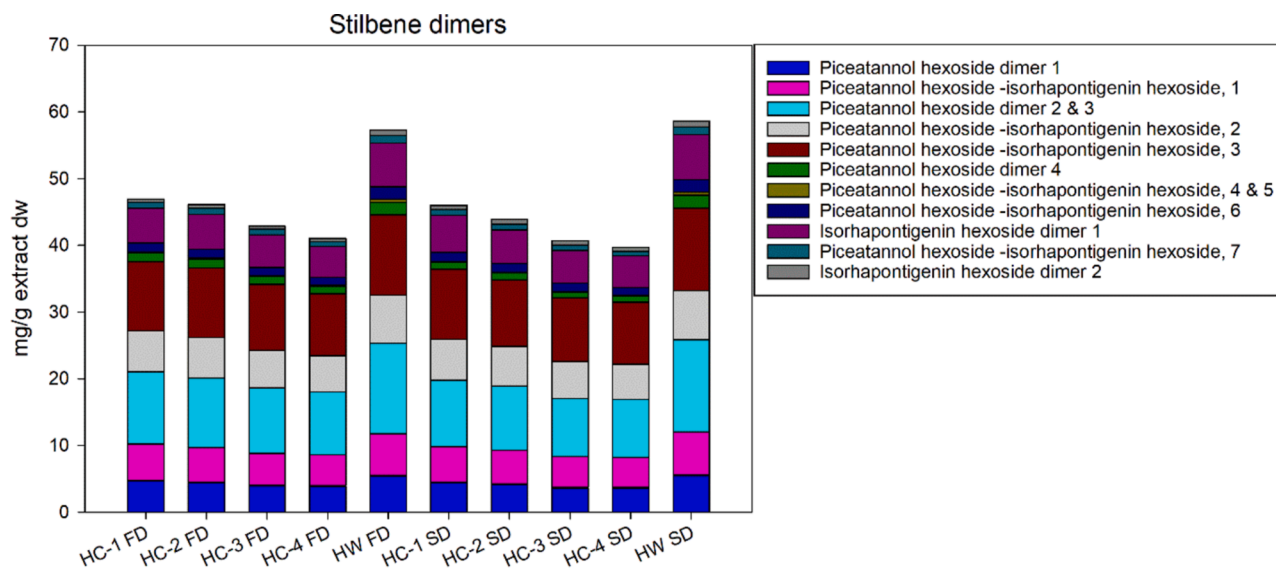

Fig. 9. Content of stilbene dimers in mg/g extract dry weight. HC = hydrodynamic cavitation extraction, HW = hot-water extraction, FD = freeze-dried and SD = spray-dried samples.

content of the extracts, purification methods like nanofiltration have previously been applied [57].

3.4.4. Terpenes and terpenoids

Because terpenes and terpenoids have been identified with strong antimicrobial activities but low antioxidant activities [4], we were motivated in seeing, if there would be evidence of differences in the terpene profiles of the extracts. These differences could explain the finding that HC extracts showed stronger antibacterial activities, while HW exhibited stronger antioxidant efficacy. However, because of the volatility of the terpenes and especially monoterpenes, the identification was made directly from the extracts before drying and the grouped terpene and terpenoid classes are shown in Fig. 11. For more detailed identification, see Supplementary Figure S2. We hypothesize that sesquiterpenes are more likely preserved in the extracts after drying, while most of the monoterpenes are likely lost during handling. Sesquiterpenes, such as β -cadinene and cubenol, and diterpene alcohols like thunbergol, seem to indeed be more abundant in the HC extracts, which could suggest that they could play a role in the elevated activities against bacteria. Moreover, as these data concern the concentration in the water extract, it should be considered that the concentration of the terpenes and terpenoids in the HC-based dry extracts, which were obtained starting from a remarkably lower solid to liquid ratio, could be higher compared to the HW-based dry extract. This might be due either to the mild temperature of the HC process, which helps retain the volatile compounds in the solution, or to the complexation of volatiles with polysaccharides, such as pectin, as observed for example with the extraction of citrus waste peel [58].

3.4.5. Elemental analysis

Both pilot-scale extraction methods use a substantial amount of water in the process and the methods were performed in different parts of Europe, HC in Italy and HW in Finland. Therefore, we wanted to see, if water quality and softness would play a role in the elemental composition, and by that also induce changes in the bioactivity profiles. The results of the elemental analyses are presented in Table 7. Krogell et al. had previously found that the most abundant metal ions of inner and outer bark were calcium and potassium, which agrees with our findings [59]. While with many elements like B, Cd, and Pb, the extracts were similar, some differences arise between the extracts. It seems that the amounts of Al, Ca, Fe, K, Mg, Mn, Na, S, and Zn were constantly lower in HW extracts, while HW extract showed higher amounts of Ni than HC

extracts, likely caused by the extraction equipment stainless steel releasing some traces of nickel. It is however important to note that as HC extracts contained originally larger volume of water, also the elemental traces are likely higher even though the water has been dried out. Interestingly, the first extraction point of HC with the lowest extraction time and temperature, seemed to have elevated concentrations of Cr and Cu in comparison to all the other HC and HW extracts. A possible explanation is the complexation of metals, especially transition metals, with tannins, boosted by the high mass transfer rate with HC processes, and increasing precipitation during the process [60]. This would explain the elevated total solids in the HC extracts (Table 3) and can also be the cause of lower tannin contents seen in section 3.4.1.

3.5. Technical feasibility analysis

3.5.1. Material balance

The detailed material streams of the HC and HW processes are presented in Supplementary Tables S3 and S4, respectively and summarized with Sankey diagrams in Fig. 12. Sankey diagrams visualize the material flows so that the width of the arrow is proportional to the flow. In the tables, dry matter contents of the bark-water suspension streams are given, as well as the total dissolved solids amounts for the water solutions. The values for the material streams are given both for the total stream, containing the dry matter and the water, as well as calculated for the dry matter only; the streams are given separately in units of kg/h and t/a (annual tons).

The values in Fig. 12 and Supplementary Tables S3 and S4 clearly show that the solid-to-liquid ratio in the HC step is much smaller compared to the corresponding characteristic of the HW process (see values for S5), leading to lower TDS concentration in the extract stream in the HC process compared to the HW process (0.7 and 2.4 wt%, respectively); similarly the volumes in S7, S11, S13, S15, and S16 are substantially higher for HC compared to the HW.

The calculated amounts of the extracted components in the HC and HW based processes are presented in Tables 8 and 9, respectively. The results correspond to the calculated final amounts of the components, but the final moisture content of the extractives powder is ignored, instead the results are presented for the dry matter of the final product.

Based on the calculated results, higher overall yield is achieved with the HW process, which has a yield of nearly 20 % compared to the yield of slightly over 15 % in the HC process (calculated based on the dry matter of the raw material); the corresponding values for production are

Table 6

Oligo- and polysaccharide and monosaccharide concentrations in mg/g of dry extract. Results are shown in averages of two measurements ± standard deviation. HC = hydrodynamic cavitation extraction, HW = hot-water extraction. Glucose (Glc), mannose (Man), galactose (Gal), xylose (Xyl), arabinose (Ara), glucuronic acid (GlcA), galactouronic acid (GalA), rhamnose (Rha), fructose (Fru), and 4-O-methyl-glucuronic acid (MeGlcA).

Monomers	Freeze-dried					Spray-dried				
	HC-1	HC-2	HC-3	HC-4	HW	HC-1	HC-2	HC-3	HC-4	HW
Man	0.0	0.0	0.0	0.0	0.0	0.0	0.193 ±0.004	0.0	0.0	0.0
Glc	71.1 ±0.3	74 ±4	77 ±4	70.3 ±0.9	59 ±3	78 ±5	72.1 ±0.9	80 ±20	75 ±3	61 ±2
Gal	13.2 ±0.3	12.89 ±0.09	13.66 ±0.02	12.5 ±0.3	12.1 ±0.6	13.8 ±0.4	11 ±4	10 ±5	12.83 ±0.13	12.37 ±0.11
Xyl	0.195 ±0.007	0.165 ±0.006	0.173 ±0.003	0.194 ±0.008	0.43 ±0.12	0.348 ±<0.001	0.142 ±0.007	0.167 ±0.008	0.174 ±0.002	0.148 ±0.002
Ara	0.241 ±0.003	0.224 ±0.006	0.236 ±0.009	0.29 ±0.10	0.76 ±0.04	0.31 ±0.12	0.335 ±<0.001	0.231 ±0.002	0.20 ±0.06	0.68 ±0.04
Rha	0.0	0.1 ±0.1	0.151 ±0.002	0.183 ±0.006	0.0	0.1 ±0.1	0.133 ±0.007	0.151 ±0.003	0.176 ±0.011	0.0
GlcA	1.65 ±0.06	1.82 ±0.05	2.01 ±0.11	2.17 ±0.03	0.63 ±0.04	1.6 ±0.4	1.77 ±0.11	1.8 ±0.5	2.3 ±0.3	0.637 ±0.012
GalA	2.42 ±0.08	2.6 ±0.3	2.538 ±0.009	2.6 ±0.5	2.05 ±0.10	5.64 ±0.09	2.40 ±0.11	2.7 ±0.4	2.343 ±0.007	2.01 ±0.09
Fru	179 ±10	169.9 ±1.0	188 ±6	179 ±8	164 ±8	186 ±7	181 ±9	180 ±20	176 ±7	164.8 ±0.6
Total	268 ±10	262 ±4	284 ±2	267 ±10	239 ±11	287 ±4	269 ±7	277 ±6	269 ±4	241.2 ±1.2
Oligo- and polysaccharides										
	Freeze-dried					Spray-dried				
	HC-1	HC-2	HC-3	HC-4	HW	HC-1	HC-2	HC-3	HC-4	HW
Man	3.8 ±0.3	2.8 ±0.2	4.11 ±0.11	3.3 ±0.3	5.1 ±0.3	3.68 ±0.06	3.7 ±0.3	3.41 ±0.08	3.4 ±0.3	4.5 ±0.4
Glc	215 ±3	202 ±7	209 ±5	210 ±30	238 ±6	198.6 ±0.4	209 ±6	201 ±5	200 ±30	230 ±20
Gal	16 ±9	20 ±2	20 ±5	24 ±3	25.2 ±0.7	19.92 ±0.12	23.6 ±0.8	27.29 ±0.13	23 ±4	23 ±3
Xyl	3.22 ±0.04	3.11 ±0.14	3.43 ±0.04	3.3 ±0.2	3.20 ±0.11	3.024 ±0.009	3.3 ±0.4	3.4 ±0.2	3.4 ±0.3	3.4 ±0.3
Ara	10.949 ±0.010	11.2 ±0.6	12.6 ±0.3	14.1 ±1.0	20.0 ±0.6	10.39 ±0.12	9.8 ±1.1	12.8 ±0.5	13.8 ±0.7	19 ±3
Rha	4.752 ±0.014	4.6 ±0.3	4.87 ±0.04	4.9 ±0.4	5.26 ±0.13	4.76 ±0.04	4.8 ±0.3	5.1 ±0.4	4.9 ±0.3	5.0 ±0.4
GlcA	1.5 ±0.5	0.59 ±0.04	1.50 ±0.07	0.5 ±0.3	1.698 ±0.003	0.4 ±0.8	1.4 ±1.0	0.9 ±0.6	0.22 ±0.11	1.6 ±0.2
GalA	23.3 ±0.5	22.4 ±1.1	23.5 ±0.3	22 ±3	34.41 ±0.14	18.8 ±0.7	22 ±3	23.6 ±0.5	23 ±3	33 ±3
4-O-Me-GlcA	3.89 ±0.07	3.84 ±0.12	4.03 ±0.06	4.0 ±0.4	4.13 ±0.14	3.8 ±0.2	3.92 ±0.14	4.1 ±0.3	4.0 ±0.3	3.8 ±0.4
Total	282 ±12	271 ±11	283 ±10	290 ±30	337 ±8	263 ±3	281 ±12	281 ±7	280 ±50	320 ±30

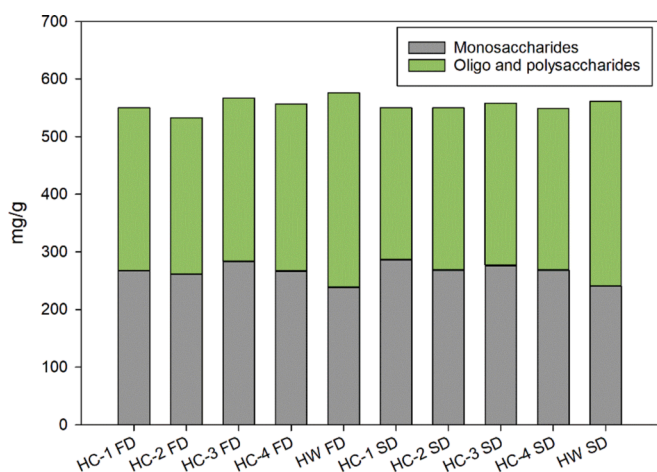

Fig. 10. Oligo and polysaccharide and monosaccharide concentrations in mg/g of dry extract. HC = hydrodynamic cavitation extraction, HW = hot-water extraction, FD = freeze-dried and SD = spray-dried samples.

2,740 and 2,130 t/a, respectively. When investigating the individual components, the terpene amounts extracted in the HC process are higher compared to the HW process, as shown in Section 3.4.4.

Apart from terpenes, all the other identified individual components have a higher final amount in the HW process compared to the HC process. The amount of the unidentified components (component named Other in Tables 8 and 9) is strikingly high, especially in the case of the HC process (28.5 wt% in the final product). Certainly, part is explained by the inorganic salts dissolved during the extraction. Other components in this category most probably include proteins, and maybe some fatty and resin acids. It is also possible that some of the dissolved components either degrade or otherwise react to unidentified compounds, such as a fraction of stilbenes missing from the HC samples, as shown in Fig. 8 and Fig. 9, converted into other products. Lignans could represent a fraction of the HC extract, which were not addressed in this study. However, the lignan concentrations are expected to be low in undamaged tree bark.

3.5.2. Energy balance

The energy consumptions of the separate process steps, as well as the total energy consumptions of the process concepts, are presented in Tables 10 and 11.

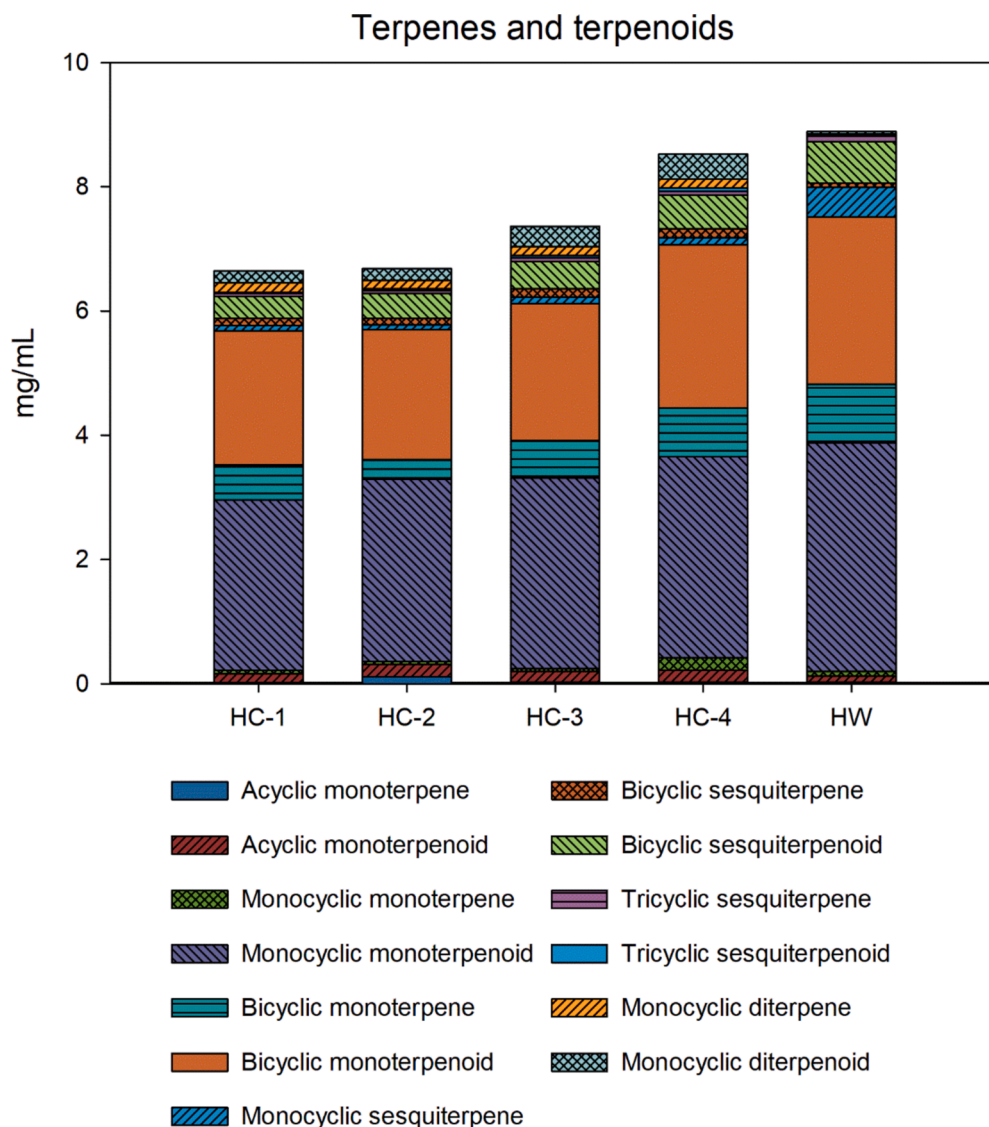

Fig. 11. Grouped terpene and terpenoid classes identified in the original (undried) extracts. More specific identification is presented in Supplementary Figure S2. HC = hydrodynamic cavitation extraction, HW = hot-water extraction.

The largest energy consumption in the HC process was identified to be the vacuum evaporation and the spray drying of the extractive solution (47.3 % and 23.1 % of the total energy consumption, respectively), whereas in the case of the HW process the energetically two highest values correspond to HW extraction and vacuum drying steps (48.0 % and 20.4 % of the total energy consumption). The high energy requirements for the water evaporation reflect the low TDS concentration in the liquid streams of the process.

For drum drying of the residual bark, no individual energy consumption was estimated. Instead, in Tables 10 and 11 it is combined in the value “Other” together with the required energy for transporting the liquids and solids in the processes with pumps and conveyer belts and screws, as well as heating energy required for the processes and the industrial premises. This total amount was estimated to be 25 % on top of the combined energy consumption of the other process steps.

As the HC treatment used as a reference for this analysis requires small particle size raw material, the energy required for the mechanical size reduction is higher in the case of HC than HW. However, in both cases the relative energy consumption of the mechanical pretreatment is very low (HC: 1.40 % of total; HW: 0.327 % of total). Also, the separation techniques for the bark suspensions suggested in the processes (decanter centrifuge, centrifugal separator, and mechanical pressing)

have only a minor contribution to the overall energy consumption.

3.5.3. Discussion on the technical feasibility analysis results

The technical feasibility analysis shows that the low concentrations of the extracted components in the liquid streams dramatically increase the calculated energy consumption of the evaporation and drying steps in the evaluated process concepts. This is especially clear in the case of the HC process.

Thus, the best route to enable the viability of the separation and drying process for the tannins and other soluble components of the bark, is to lower the liquid-to-solid ratio in the extraction step. Additionally, this would lead to decreasing the volumes of the liquid streams, making the required equipment smaller and technologically less demanding. Another, smaller direct contribution to the sustainability of the HC process would be the allowance of greater sized particles of the processed resource. Such improvements are also intertwined, since fine size material from softwood tends to float in the main vessel of the HC installation, thereby hindering its circulation through the HC reactor and the achievement of high solid-to-liquid ratio.

In contrast, the HC treatment is very fast and can be carried out at lower temperature compared to the HW step (33 °C & 25 min and 67 °C & 60 min, respectively), which is reflected in the energy consumption

Table 7

Elemental analysis of the extracts in mg/kg. HC = hydrodynamic cavitation extraction, HW = hot-water extraction.

Element	Freeze-dried					Spray-dried				
	HC-1	HC-2	HC-3	HC-4	HW	HC-1	HC-2	HC-3	HC-4	HW
Al	220 ±20	210 ±20	220 ±20	74 ±6	126 ±9	230 ±20	210 ±20	220 ±30	210 ±20	124 ±9
B	19 ±4	18 ±4	17 ±4	18 ±4	19 ±4	19 ±4	18 ±4	18 ±4	18 ±4	19 ±4
Ca	5,600 ±400	5,400 ±400	5,500 ±400	5,500 ±400	3,300 ±300	5,900 ±400	5,600 ±400	5,600 ±400	5,500 ±400	3,400 ±300
Cd*	<0.1	<0.1	<0.1	<0.1	<0.1	<0.1	<0.1	<0.1	<0.1	<0.1
Cr	1.06 ±0.14	0.51 ±0.07	0.62 ±0.09	0.80 ±0.11	0.84 ±0.12	1.2 ±0.2	0.55 ±0.08	0.68 ±0.09	0.79 ±0.11	0.84 ±0.11
Cu	8.3 ±0.8	7.1 ±0.7	5.8 ±0.6	7.3 ±0.7	5.6 ±0.6	13.9 ±1.3	9.0 ±0.9	7.9 ±0.8	8.2 ±0.8	5.8 ±0.6
Fe	57 ±5	58 ±6	56 ±5	57 ±5	31 ±3	60 ±6	31 ±6	58 ±6	58 ±5	31 ±3
K	10,400 ±1,200	10,000 ±1,100	10,300 ±1,200	10,400 ±1,200	7,900 ±900	10,200 ±1,200	10,100 ±1,200	10,200 ±1,200	10,100 ±1,200	8,000 ±900
Mg	2,000 ±120	1,950 ±120	2,000 ±120	1,990 ±120	910 ±60	2,020 ±130	1,980 ±120	2,120 ±130	2,000 ±120	920 ±60
Mn	620 ±50	600 ±50	620 ±50	620 ±50	370 ±30	630 ±50	620 ±50	630 ±50	630 ±50	370 ±30
Na	3,000 ±300	2,900 ±300	2,900 ±200	2,900 ±200	1,220 ±80	3,100 ±300	2,900 ±200	3,000 ±300	2,900 ±200	1,260 ±80
Ni	4.1 ±0.4	3.9 ±0.3	4.1 ±0.4	1.82 ±0.13	6.0 ±0.5	4.1 ±0.4	4.5 ±0.4	4.3 ±0.4	4.5 ±0.4	6.1 ±0.5
Pb*	<2.06	<2.02	<2.00	<2.07	<2.10	<2.11	<2.05	<2.06	<2.10	<2.09
P	840 ±100	840 ±100	870 ±100	290 ±40	870 ±100	840 ±100	850 ±100	880 ±110	890 ±110	870 ±100
S	2,400 ±300	2,300 ±200	2,400 ±300	720 ±60	690 ±50	2,400 ±200	2,300 ±200	2,400 ±200	2,300 ±200	700 ±60
Zn	146 ±12	134 ±11	132 ±11	44 ±4	103 ±9	151 ±13	136 ±11	140 ±12	140 ±12	104 ±9

*Content under determination limit in all the samples.

values of these steps: 37,228 MWh/a for HW and 5,811 MWh/a for HC.

The milder extraction conditions afforded by HC and consequently higher extraction stage yield (unit mass of TDS obtained from a unit energy consumption, as per Table 3), along with the higher antibacterial activities of the respective extracts, represent sufficient motivation for further research aimed at overcoming the limitations of HC extraction processes and open the way to their industrialization. Research should focus on structural and process arrangement and optimization to accommodate higher biomass concentration. The first practical recommendation is to use open impeller pumps or other technical variants aimed at preventing clogging in the pump body, which could also enable the processing of larger biomass particles. Another practical recommendation is to limit the accumulation of insoluble solids by performing repeated cycles of partial biomass loading, extraction, separation and clarification, and reloading the clarified aqueous extract into the HC device.

However, with increasing biomass concentration, a decrease of extraction yield was observed, e.g. for almonds [64] and chestnut [65], yet insufficient to reverse the comparative advantage of the higher concentration trials. This evidence could be related to the circulating aqueous mixture getting increasingly loaded with soluble extractives, which increases its viscosity. Indeed, a recent study directly showed that with increasing liquid viscosity, a fast decrease of the pressure peak and energy of the primary pressure shockwaves generated after bubble collapse occurred, along with the thickening of the shockwave front, leading to decreased pressure gradient [66].

Thus, cavitation intensification is recommended as a priority topic for fundamental and industrial research. For example, a recent modeling and experimentally validated study demonstrated how a simple structural arrangement, consisting in a semi-circular annular protrusion located at a certain distance downstream the throat of a static circular venturi-shaped reactor, was able to remarkably intensify the generated cavitation, in terms of vapor volume fraction, peak collapse pressure and temperature, and generation of ·OH radicals [67]. This result shows

ample room for cavitation intensification even using quite simple HC reactors.

Based on the relationship between the density and the collapse intensity of cavitation bubbles, and the cavitation number in static HC reactors [68], a combination of a suitable reactor geometry, such as the above-described one [67], and using an inverter to tune the pump frequency, which directly affects the cavitation number, might allow coping with a wide range of liquid viscosity levels.

The extraction technique comparison is presented in Table 12. However, it is still too early to decide which process, HW or HC, is more recommended. First, based on the performed experiments, the distinct functionalities of the extracts were affected in different directions by the extraction methods. Second, in terms of energy balance, HC outperformed HW in the extraction process, while the opposite occurred when considering the entire process chain; in principle, HC has large scope for improving the overall energy balance, but the feasibility of such improvement needs to be demonstrated.

Although the main subject of this paper was the extraction of tannins and other valuable soluble components from bark, it is worthwhile remembering that another important product from the extraction process is the solid fraction, namely the bark insoluble residue (calculated to be 11,532 ODT/a for the HC process and 10,927 ODT/a for the HW process). One straightforward option for balancing the energy demand of the processes would be to combust the bark residue for heat and power, but also other possibilities can be envisioned including pyrolysis to oil and biochar or utilizing the residue for manufacturing composites [71].

Considerable amount of commercial plant extraction methods relies on the use of organic solvents. The boiling point of water is higher than the boiling point of many organic solvents. Therefore, replacing water partially or completely with e.g., ethanol would certainly lower the energy consumption during the solvent evaporation. However, including ethanol would increase the operating pressure and its feasible use would require an efficient recovery system. As these features would

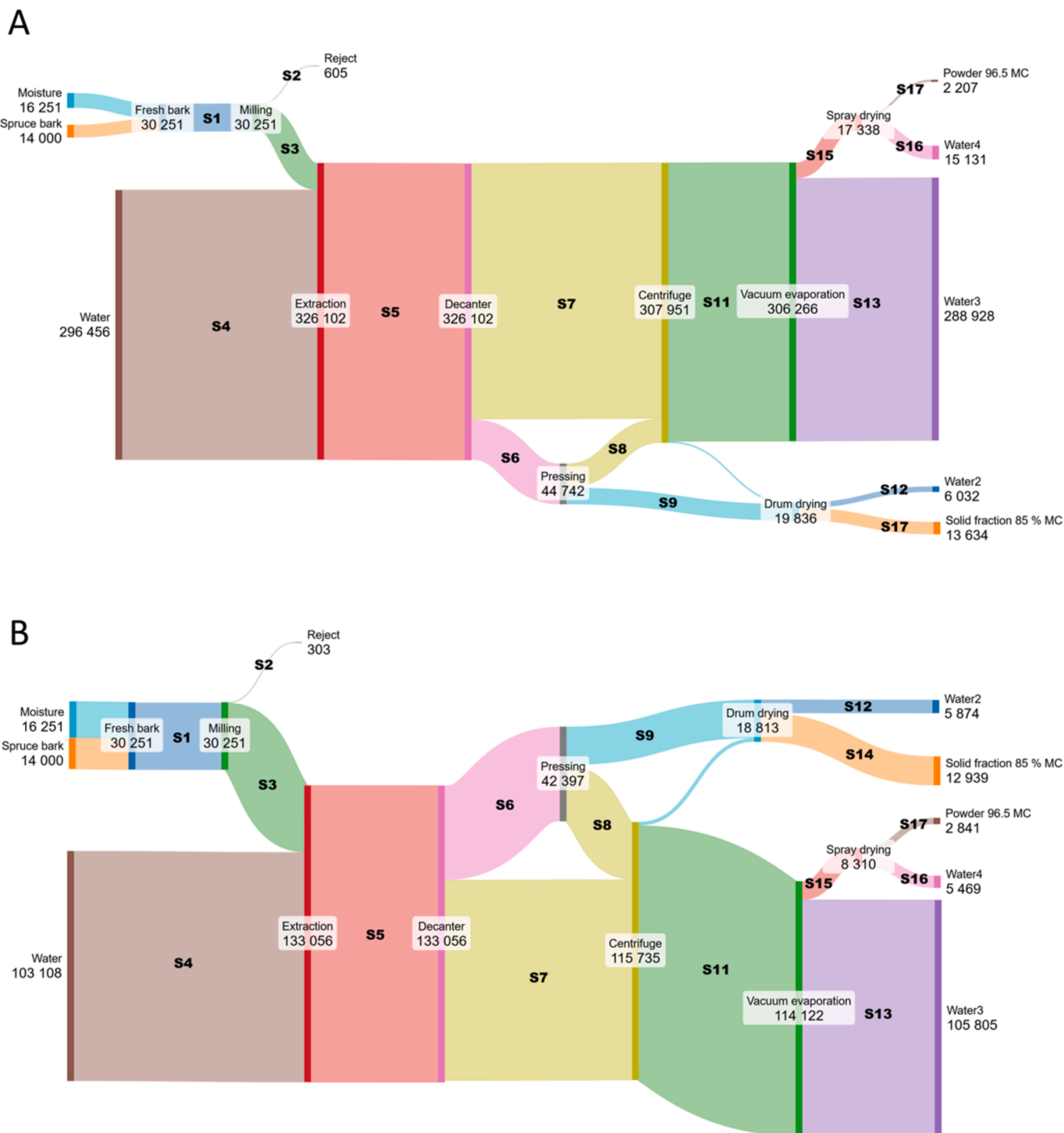

Fig. 12. Sankey diagrams for the material flow charts of the hydrodynamic cavitation HC (A) and hot-water extraction HW (B) processes. All the units are presented in annual tons (t/a). The symbols of the streams (S1-S17) correspond to the symbols in Fig. 2 in Materials and Methods section. Detailed material stream in Supplementary Tables S3 and S4.

significantly complicate the process design, and as water is generally seen as the recommended solvent of choice of the green extraction principles [69,70], the option of utilizing organic solvents is not discussed further in this context. An important commercial process, quite relevant to the subject investigated in this study, concerned the production of Pycnogenol®, a phytocomplex extracted from the bark of French maritime pine and titred in oligomeric proanthocyanidins (OPC) at the level of 70 ± 5 %, which has been marketed since the 1980 s', whose biological functions were investigated in tens of clinical trials

[72]. The primary extraction of the bark of French maritime pine (before a multi-step purification process aimed at achieving the high OPC titre) was performed in water only, generally at boiling temperature [73]. However, the relevant patents (in particular, patent No. FR2643073A1 [74]) disclosed only the allowed water temperature range (4 to 100 °C), while suggesting that the process time should be decided based on the water temperature. No information was available about the energy consumption, while the solid-to-liquid ratio in boiling water was documented at the level of 1:6 [73]. Thus, the main takeaway from this very

Table 8

Hydrodynamic cavitation (HC) results: composition of the final product stream. The moisture contained by the final product (DMC 96.5 wt%) is not included but the composition is given in complete dryness. The total annual production (ODT/a) of the individual components, as well as the extractives powder, is given. Also, the wt.% of the components in the powder, and their yield based on oven-dried (OD) bark, are given. The component Other refers to unidentified compound; t/a = annual tons; 4-O-Me-GlcA = 4-O-methylglucuronic acid.

Component	t/a	wt.%	Yield based on OD bark, wt.%
Condensed tannins	413	19.4	2.95
Stilbenes	168	7.90	1.20
Total terpenes	2.07	0.10	0.01
Total sugars	941	44.2	6.72
Mannan	5.96	0.28	0.04
Glucan	430	20.2	3.07
Galactan	43.4	2.04	0.31
Xylan	6.60	0.31	0.05
Arabinan	23.8	1.12	0.17
Rhamnan	9.79	0.46	0.07
Glucuronic acid	3.83	0.18	0.03
Galacturonic acid	47.7	2.24	0.34
Fructose	362	17.0	2.58
4-O-Me-GlcA	8.09	0.38	0.06
Other	606	28.5	4.33
Total	2,130	100	15.21

Table 9

Hot-water extraction (HW) results: composition of the final product. The moisture contained by the final product (DMC 96.5 wt%) is not included but the composition is given in complete dryness. The total annual production (ODT/a) of the individual components, as well as the extractives powder, is given. Also, the wt.% of the components in the powder, and their yield based on OD bark, are given. The component Other refers to unidentified compounds; t/a = annual tons; 4-O-Me-GlcA = 4-O-methylglucuronic acid.

Component	t/a	wt.%	Yield based on OD bark, wt.%
Condensed tannins	688	25.1	4.91
Stilbenes	282	10.3	2.02
Total terpenes	1.01	0.04	0.01
Total sugars	1,360	49.6	9.70
Mannan	11.8	0.43	0.08
Glucan	658	24.0	4.70
Galactan	71.5	2.61	0.51
Xylan	8.77	0.32	0.06
Arabinan	47.4	1.73	0.34
Rhamnan	14.8	0.54	0.11
Glucuronic acid	4.93	0.18	0.04
Galacturonic acid	80.3	2.93	0.57
Fructose	449	16.4	3.21
4-O-Me-GlcA	11.5	0.42	0.08
Other	412	15.0	2.94
Total	2,740	100	19.57

successful business story is, again, the need to increase the solid-to-liquid ratio in the application described in this study, at least until the level of 1:6 and hopefully even higher.

The extraction and isolation process could be integrated also to pulp mills or combined heat and power plants to utilize waste heat of these processes. Another option in future could be utilizing waste heat from datacenters that provide uninterrupted waste heat during their operation e.g. in extraction, evaporation and dryings steps [75]. It is estimated that information and communication technology will consume 23 % of global energy demand in 2030 creating substantial amount of waste heat.

4. Conclusion

In conclusion, we demonstrated that industrial scale assortment and green pilot-scale extraction methods are usable and efficient in

Table 10

Estimated energy consumption of the individual process steps and the total energy consumption of the hydrodynamic cavitation (HC) extraction process. NA = not applicable.

Equipment	Energy consumption			
	kWh/t	MWh/a	kWh/h	% of total
Mill	22.73 ^a	1,368	162.9	1.40
HC extraction unit	196.0 ^a	5,811	691.7	6.33
Decanter centrifuge	1.700 ^b	554	66.00	0.605
Centrifugal separator	1.000 ^b	305	36.33	0.333
Press	30.00 ^c	789	93.99	0.861
Vacuum evaporator	150.0 ^c	43,339	5,159	47.3
Spray dryer	1,400 ^c	21,183	2,522	23.1
Other ^d	NA	18,337	2,183	20.0
Total	NA	91,687	10,915	100

^a)based on ton material processed; values from experiments reported in this paper, considering that the bark sample was milled twice.

^b)based on ton material processed; values from literature[61,62].

^c)based on ton of water removed; values from literature [63] and from equipment manufacturers.

^d)authors' estimation on combined energy requirement of drum drying of the residual bark, pumps, conveyers, heating energy for the premises etc.

Table 11

Estimated energy consumption of the individual process steps and the total energy consumption of the hot-water (HW) extraction process. NA = not applicable.

Equipment	Energy consumption			
	kWh/t	MWh/a	kWh/h	% of total
Shredder	8.400 ^a	254.1	30.25	0.327
HW extraction reactor	2,686 ^a	37,228	4,432	48.0
Decanter centrifuge	1.700 ^b	226	26.93	0.291
Centrifugal separator	1.000 ^b	112	13.37	0.145
Press	30.00 ^c	748	89.08	0.964
Vacuum evaporator	150.0 ^c	15,872	1,889	20.4
Spray dryer	1,400 ^c	7,656	911.5	9.86
Other ^d	NA	15,524	1,848	20.0
Total	NA	77,621	9,241	100

^a)based on ton material processed; values from experiments reported in this paper.

^b)based on ton material processed; values from literature[61,62].

^c)based on ton of water removed; values from literature [63] and from equipment manufacturers.

^d)authors' estimation on combined energy requirement of drum drying of the residual bark, pumps, conveyers, heating energy for the premises etc.

recovering polyphenolic compounds, such as condensed tannins and stilbenes, with antimicrobial and antioxidant properties.

We also showed that the extraction and handling conditions affected the compound composition and bioactive profile of the extracts. HC extracts exhibited higher antibacterial activities, which can likely be attributed to the higher contents of terpenoids and especially sesquiterpenoids but lower total amount of carbohydrates when compared with HW extracts. In contrast, the HW extracts yielded a higher concentration of condensed tannins and stilbenes, which likely induced slightly higher antioxidant and antiviral activities. It is, however, important to note that because of systemic requirements, there were differences in the particle size and solid-to-liquid ratio of the extractions, which can also affect the results.

Based on the promising results obtained *in vitro* with the antimicrobial activity, both antibacterial and antiviral, using different extracts of Norway spruce bark, further research is recommended on more biologically relevant assays, such as *in vivo* or even clinical trials, supported by the comprehensive chemical composition analysis performed in this study.

Finally, a technical feasibility analysis showed that the critical, most energy-consuming step, of pilot to industrial scale upscaling was the

Table 12

Comparison of the extraction techniques. HC = hydrodynamic cavitation extraction, HW = hot-water extraction.

Factor	HC	HW	Comment
Solvent	+++	+++	Water is safe, not hazardous, environmentally friendly solvent compared to organic solvents [69,70]
Raw material	+	+++	HC requires raw material to be milled to lower particle size
Liquid to solids	++	+++	HW extraction has lower liquid to solids ratio compared to HC, yielding higher concentration extract
Extraction temperature & pressure	+++	++	Both HC and HW are effective at moderate temperatures and room pressure. HC is more effective at lower temperatures.
Extraction stage yield	+++	+	HC affords higher extraction stage yield (TDS per unit consumed energy) due to shorter extraction time and lower working temperature.
Bioactivities	+++	+++	HW extract has slightly higher antioxidant and antiviral activity, while HC extracts have higher antibacterial activity
Scalability	++	+++	HW is ready for scale-up. HC has potential for scale-up, mainly conditioned on lower liquid to solid ratio while preserving the extraction yield

water evaporation and drying of the dilute extracts, thus pointing out the need for as high as possible solid to liquid ratio of the processed mixture.

Declaration of competing interest

The authors declare that they have no known competing financial interests or personal relationships that could have appeared to influence the work reported in this paper.

Acknowledgements

This study was supported by the Academy of Finland funded project ForestAntivirals, decision no. 342250. Authors express gratitude towards Piia Grandell, Ulla Jauhiainen, Pauli Karppinen, and Sara Turunen for the proficient technical laboratory analyses at Luke laboratories. The authors also thank Kirsi S. Mikkonen and Thao Minh Ho from University of Helsinki for the kind help with spray-drying of the samples and Jarkko Hellström (Luke) for the enriching discussion about tannin analytics. Author F.M. was also funded by the following projects: PNRR (National Recovery and Resilience Plan)—Mission 4, Component 2, Investment 1.3, Italian Ministry of University and Research, funded by the European Union NextGenerationEU—Project PE0000003 (PE10 ON Foods: Research and innovation network on food and nutrition Sustainability, Safety and Security—Working ON Foods; Spoke 2 “Smart and circular food system and distribution”), Concession Decree No. 1550 of 11 October 2022; and CNR project “NutraGe” FOE-2021 DBA. AD005.225. Authors L.M. and V.M. also thank Jane and Aatos Erkkö foundation (grant number 240002).

Appendix A. Supplementary data

Supplementary data to this article can be found online at <https://doi.org/10.1016/j.seppur.2024.130925>.

Data availability

Data will be made available on request.

References

- [1] Forest industries' wood consumption 2023, Natural Resources Institute Finland (2023). <https://www.luke.fi/en/statistics/wood-consumption/forest-industrie-s-wood-consumption-2023> (accessed August 21, 2024).
- [2] D. Jinze, M. Evgen, D. Xinyue, W. Lei, V. Tapani, Valorization of long-neglected spruce bark and bark-press effluents through integrated utilization of stilbenoids and pectin, *Chem Eng J* 470 (2023) 144122, <https://doi.org/10.1016/j.cej.2023.144122>.
- [3] K. Bhardwaj, A.S. Silva, M. Atanassova, R. Sharma, E. Nepovimova, K. Musilek, R. Sharma, M.A. Alghuthaymi, D.S. Dhanjal, M. Nicoletti, B. Sharma, N. K. Upadhyay, N. Cruz-Martins, P. Bhardwaj, K. Kuća, Conifers Phytochemicals: A Valuable Forest with Therapeutic Potential, *Molecules* 26 (2021) 3005, <https://doi.org/10.3390/molecules26103005>.
- [4] R. Muilu-Mäkelä, U. Aapola, J. Tienaho, H. Uusitalo, T. Sarjala, Antibacterial and Oxidative Stress-Protective Effects of Five Monoterpenes from Softwood, *Molecules* 27 (2022) 3891, <https://doi.org/10.3390/molecules27123891>.
- [5] A.-L. Välimaa, J.-E. Raitanen, J. Tienaho, T. Sarjala, E. Nakayama, R. Korpinen, S. Mäkinen, P. Eklund, S. Willför, T. Jyske, Enhancement of Norway spruce bark side-streams: Modification of bioactive and protective properties of stilbenoid-rich extracts by UVA-irradiation, *Ind Crops Prod* 145 (2020) 112150, <https://doi.org/10.1016/j.indcrop.2020.112150>.
- [6] J.-E. Raitanen, E. Järvenpää, R. Korpinen, S. Mäkinen, J. Hellström, P. Kilpeläinen, J. Liimatainen, A. Ora, T. Tupasela, T. Jyske, Tannins of Conifer Bark as Nordic Piquancy—Sustainable Preservative and Aroma? *Molecules* 25 (2020) 567, <https://doi.org/10.3390/molecules25030567>.
- [7] A.S. Ristinmaa, A. Tafur Rangel, A. Idström, S. Valenzuela, E.J. Kerkhoven, P. B. Pope, M. Hasani, J. Larsbrink, Resin acids play key roles in shaping microbial communities during degradation of spruce bark, *Nat Commun* 14 (2023) 8171, <https://doi.org/10.1038/s41467-023-43867-y>.
- [8] T. Holmbom, M. Reunanen, P. Fardim, Composition of callus resin of Norway spruce, Scots pine, European larch and Douglas fir, *Holzforchung* 62 (2008) 417–422, <https://doi.org/10.1515/HF.2008.070>.
- [9] S. Willför, J. Hemming, M. Reunanen, C. Eckerman, B. Holmbom, Lignans and Lipophilic Extractives in Norway Spruce Knots and Stemwood, *Holzforchung* 57 (2003) 27–36, <https://doi.org/10.1515/HF.2003.005>.
- [10] H. Latva-Mäenpää, T. Laakso, T. Sarjala, K. Wähälä, P. Saranpää, Root neck of Norway spruce as a source of bioactive lignans and stilbenes, *Holzforchung* 68 (2014) 1–7, <https://doi.org/10.1515/hf-2013-0020>.
- [11] R. Anuceanu, A.I. Anghel, M.V. Hovanet, A.-M. Ciobanu, B.E. Lascu, M. Dinu, Antioxidant Activity of Essential Oils from Pinaceae Species, *Antioxidants* 13 (2024) 286, <https://doi.org/10.3390/antiox13030286>.
- [12] S. Häslér Gunnarsdottir, L. Sommerauer, T. Schnabel, G.J. Oostingh, A. Schuster, Antioxidative and Antimicrobial Evaluation of Bark Extracts from Common European Trees in Light of Dermal Applications, *Antibiotics* 12 (2023) 130, <https://doi.org/10.3390/antibiotics12010130>.
- [13] S. Shroff, A. Perämäki, A. Väisänen, P. Pasanen, K. Grönlund, V.H. Nissinen, J. Jänis, A. Haapala, V. Marjomäki, Tree Species-Dependent Inactivation of Coronaviruses and Enteroviruses on Solid Wood Surfaces, *ACS Appl Mater Interfaces* 16 (2024) 29621–29633, <https://doi.org/10.1021/acsmi.4c02156>.
- [14] P.O. Kilpeläinen, S.S. Hautala, O.O. Byman, L.J. Tanner, R.I. Korpinen, M.-K.-J. Lillandt, A.V. Pranovich, V.H. Kitunen, S.M. Willför, H.S. Ilvesniemi, Pressurized hot water flow-through extraction system scale up from the laboratory to the pilot scale, *Green Chem* 16 (2014) 3186–3194, <https://doi.org/10.1039/C4GC00274A>.
- [15] R. Mittal, V.V. Ranade, Intensifying extraction of biomolecules from macroalgae using vortex based hydrodynamic cavitation device, *Ultrason Sonochem* 94 (2023) 106347, <https://doi.org/10.1016/j.ultrsonch.2023.106347>.
- [16] L. Albanese, A. Bonetti, L. D'Acqui, F. Meneguzzo, F. Zabini, Affordable Production of Antioxidant Aqueous Solutions by Hydrodynamic Cavitation Processing of Silver Fir (*Abies alba* Mill.) Needles, *Foods* 8 (2019) 65, <https://doi.org/10.3390/foods8020065>.
- [17] F. Meneguzzo, C. Brunetti, A. Fidalgo, R. Ciriminna, R. Delisi, L. Albanese, F. Zabini, A. Gori, L. Dos Santos Nascimento, A. De Carlo, F. Ferrini, L. Ilharco, M. Pagliaro, Real-Scale Integral Valorization of Waste Orange Peel via Hydrodynamic Cavitation, *Processes* 7 (2019) 581, <https://doi.org/10.3390/pr7090581>.
- [18] F. Meneguzzo, L. Albanese, F. Zabini, Hydrodynamic Cavitation in Beer and Other Beverage Processing, in: *Innovative Food Processing Technologies*, Elsevier, 2021, pp. 369–394, <https://doi.org/10.1016/B978-0-08-100596-5.23022-9>.
- [19] P. Kilpeläinen, E. Liski, P. Saranpää, Optimising and scaling up hot water extraction of tannins from Norway spruce and Scots pine bark, *Ind Crops Prod* 192 (2023) 116089, <https://doi.org/10.1016/j.indcrop.2022.116089>.
- [20] W.D. Loomis, J. Battaile, Plant phenolic compounds and the isolation of plant enzymes, *Phytochemistry* 5 (1966) 423–438, [https://doi.org/10.1016/S0031-9422\(00\)82157-3](https://doi.org/10.1016/S0031-9422(00)82157-3).
- [21] S. Vesterlund, J. Palta, A. Lauková, M. Karp, A. Ouwehand, Rapid screening method for the detection of antimicrobial substances, *J Microbiol Methods* 2004 (2004) 23–31, <https://doi.org/10.1016/j.mimet.2003.11.014>.
- [22] J. Tienaho, D. Reshamwala, T. Sarjala, P. Kilpeläinen, J. Liimatainen, J. Dou, A. Viherä-Aarnio, R. Linnakoski, V. Marjomäki, T. Jyske, Salix spp. Bark Hot Water Extracts Show Antiviral, Antibacterial, and Antioxidant Activities—The Bioactive Properties of 16 Clones, *Front Bioeng Biotechnol* 9 (2021) 797939, <https://doi.org/10.3389/fbioe.2021.797939>.
- [23] M. Myllynen, A. Kazmertsuk, V. Marjomäki, A Novel Open and Infectious Form of Echovirus 1, *J Virol* 90 (2016) 6759–6770, <https://doi.org/10.1128/JVI.00342-16>.

- [24] I.F.F. Benzie, J.J. Strain, The Ferric Reducing Ability of Plasma (FRAP) as a Measure of "Antioxidant Power": The FRAP Assay, *Anal Biochem* 239 (1996) 70–76, <https://doi.org/10.1006/abio.1996.0292>.
- [25] D. Huang, B. Ou, M. Hampsch-Woodill, J.A. Flanagan, R.L. Prior, High-Throughput Assay of Oxygen Radical Absorbance Capacity (ORAC) Using a Multichannel Liquid Handling System Coupled with a Microplate Fluorescence Reader in 96-Well Format, *J Agric Food Chem* 50 (2002) 4437–4444, <https://doi.org/10.1021/jf0201529>.
- [26] R.L. Prior, H. Hoang, L. Gu, X. Wu, M. Bacchiocca, L. Howard, M. Hampsch-Woodill, D. Huang, B. Ou, R. Jacob, Assays for Hydrophilic and Lipophilic Antioxidant Capacity (oxygen radical absorbance capacity (ORACFL)) of Plasma and Other Biological and Food Samples, *J Agric Food Chem* 51 (2003) 3273–3279, <https://doi.org/10.1021/jf0262256>.
- [27] J. Tienaho, M. Karonen, R. Muilu-Mäkelä, J. Kaseva, N. de Pedro, F. Vicente, O. Genilloud, U. Aapola, H. Uusitalo, K. Vuolteenaho, R. Franzén, K. Wähälä, M. Karp, V. Santala, T. Sarjala, Bioactive Properties of the Aqueous Extracts of Endophytic Fungi Associated with Scots Pine (*Pinus sylvestris*) Roots, *Planta Med* 86 (2020) 1009–1024, <https://doi.org/10.1055/a-1185-4437>.
- [28] E.A. Ainsworth, K.M. Gillespie, Estimation of total phenolic content and other oxidation substrates in plant tissues using Folin–Ciocalteu reagent, *Nat Protoc* 2 (2007) 875–877, <https://doi.org/10.1038/nprot.2007.102>.
- [29] V.L. Singleton, R. Orthofer, R.M. Lamuela-Raventós, Analysis of total phenols and other oxidation substrates and antioxidants by means of folin–ciocalteu reagent, in: *Methods in Enzymology*, 299, Elsevier, 1999, pp. 152–178, [https://doi.org/10.1016/S0076-6879\(99\)99017-1](https://doi.org/10.1016/S0076-6879(99)99017-1).
- [30] V.L. Singleton, J.A. Rossi, Colorimetry of Total Phenolics with Phosphomolybdic-Phosphotungstic Acid Reagents, *Am J Enol Vitic* 16 (1965) 144–158, <https://doi.org/10.5344/ajev.1965.16.3.144>.
- [31] S.G. Reeves, A. Somogyi, W.E. Zeller, T.A. Ramelot, K.C. Wrigton, A.E. Hagerman, Proanthocyanidin Structural Details Revealed by Ultrahigh Resolution FT-ICR MALDI-Mass Spectrometry, 1H–13C HSQC NMR, and Thiolytic-HPLC–DAD, *J Agric Food Chem* 68 (2020) 14038–14048, <https://doi.org/10.1021/acs.jafc.0c04877>.
- [32] A.N. Scioneaux, M.A. Schmidt, M.A. Moore, R.L. Lindroth, S.C. Wooley, A. E. Hagerman, Qualitative Variation in Proanthocyanidin Composition of Populus Species and Hybrids: Genetics is the Key, *J Chem Ecol* 37 (2011) 57–70, <https://doi.org/10.1007/s10886-010-9887-y>.
- [33] A.E. Hagerman, M.E. Rice, N.T. Ritchard, Mechanisms of Protein Precipitation for Two Tannins, Pentagalloyl Glucose and Epicatechin₁₆ (4→8) Catechin (Procyanidin), *J Agric Food Chem* 46 (1998) 2590–2595, <https://doi.org/10.1021/jf971097k>.
- [34] H. Naumann, R. Sepela, A. Rezaire, S. Masih, W. Zeller, L. Reinhardt, J. Robe, M. Sullivan, A. Hagerman, Relationships between Structures of Condensed Tannins from Texas Legumes and Methane Production During In Vitro Rumen Digestion, *Molecules* 23 (2018) 2123, <https://doi.org/10.3390/molecules23092123>.
- [35] M. Karonen, I.B. Imran, M.T. Engström, J.-P. Salminen, Characterization of Natural and Alkaline-Oxidized Proanthocyanidins in Plant Extracts by Ultrahigh-Resolution UHPLC-MS/MS, *Molecules* 26 (2021) 1873, <https://doi.org/10.3390/molecules26071873>.
- [36] R.O. Miller, Microwave digestion of plant tissue in a closed vessel, in: *Handbook of reference methods for plant analysis*, CRC Press, 2019, pp. 69–73.
- [37] A. Sundberg, K. Sundberg, C. Lillandt, B. Holmbom, Determination of hemicelluloses and pectins in wood and pulp fibres by acid methanolysis and gas chromatography, *Nord Pulp Pap Res J* 11 (1996) 216–219, <https://doi.org/10.3183/npprj-1996-11-04-p216-219>.
- [38] V. Heiskanen, P. Rikonen, Bark amount in coniferous sawlogs and factors affecting it, 1976 (1976). <http://urn.fi/URN:ISBN:951-40-0257-1>.
- [39] Our sawmills, SCA (2024). <https://www.sca.com/en/wood/our-sawmills/> (accessed August 21, 2024).
- [40] T. Jyske, H. Brännström, T. Sarjala, J. Hellström, E. Halmemies, J.-E. Raitanen, J. Kaseva, L. Lagerquist, P. Eklund, J. Nurmi, Fate of Antioxidative Compounds within Bark during Storage: A Case of Norway Spruce Logs, *Molecules* 25 (2020) 4228, <https://doi.org/10.3390/molecules25184228>.
- [41] N. Pap, D. Reshamwala, R. Korpinen, P. Kilpeläinen, M. Fidelis, M.M. Furtado, A. S. Sant'Ana, M. Wen, L. Zhang, J. Hellström, P. Marnilla, P. Mattila, T. Sarjala, B. Yang, A.D.S. Lima, L. Azevedo, V. Marjomäki, D. Granato, Toxicological and bioactivity evaluation of blackcurrant press cake, sea buckthorn leaves and bark from Scots pine and Norway spruce extracts under a green integrated approach, *Food Chem Toxicol* 153 (2021) 112284, <https://doi.org/10.1016/j.fct.2021.112284>.
- [42] M.K. Abban, E.A. Ayerakwa, L. Mosi, A. Isawumi, The burden of hospital acquired infections and antimicrobial resistance, *Heliyon* 9 (2023) e20561, <https://doi.org/10.1016/j.heliyon.2023.e20561>.
- [43] S. Kunnas, J. Tienaho, T. Holmbom, S. Sutela, J. Liimatainen, K. Kaipainen, R. Jääskeläinen, S. Sääski, R.I. Korpinen, Antimicrobial treatments with chitosan microencapsulated angelica (*Angelica archangelica*) and marsh Labrador tea (*Rhododendron tomentosum*) supercritical CO₂ extracts in linen-cotton jacquard woven textiles, *Text Res J* (2024) 00405175241247024, <https://doi.org/10.1177/00405175241247024>.
- [44] K. Kempainen, M. Siika-aho, S. Pattathil, S. Giovando, K. Kruus, Spruce bark as an industrial source of condensed tannins and non-cellulosic sugars, *Ind Crops Prod* 52 (2014) 158–168, <https://doi.org/10.1016/j.indcrop.2013.10.009>.
- [45] A.E. Hagerman, Fifty Years of Polyphenol–Protein Complexes, in: V. Cheynier, P. Sarni-Manchado, S. Quideau (Eds.), *Recent Advances in Polyphenol Research*, 1st ed, Wiley, 2012, pp. 71–97, <https://doi.org/10.1002/9781118299753.ch3>.
- [46] T. Varila, H. Brännström, P. Kilpeläinen, J. Hellström, H. Romar, J. Nurmi, U. Lassi, From Norway Spruce Bark to Carbon Foams: Characterization, and Applications, *BioResources* 2020 (2020) 3651–3666, <https://doi.org/10.15376/biores.15.2.3651-3666>.
- [47] S. Metsämuuronen, H. Sirén, Bioactive phenolic compounds, metabolism and properties: a review on valuable chemical compounds in Scots pine and Norway spruce, *Phytochem Rev* 18 (2019) 623–664, <https://doi.org/10.1007/s11101-019-09630-2>.
- [48] T. Jyske, J. Liimatainen, J. Tienaho, H. Brännström, D. Aoki, K. Kuroda, D. Reshamwala, S. Kunnas, E. Halmemies, E. Nakayama, P. Kilpeläinen, A. Ora, J. Kaseva, J. Hellström, V.S. Marjomäki, M. Karonen, K. Fukushima, Inspired by nature: Fiber networks functionalized with tannic acid and condensed tannin-rich extracts of Norway spruce bark show antimicrobial efficacy, *Front Bioeng Biotechnol* 11 (2023) 1171908, <https://doi.org/10.3389/fbioe.2023.1171908>.
- [49] S. Quideau, D. Deffieux, C. Douat-Casassus, L. Pouyssegou, Plant Polyphenols: Chemical Properties, Biological Activities, and Synthesis, *Angew Chem Int Ed* 50 (2011) 586–621, <https://doi.org/10.1002/anie.201000044>.
- [50] G. Gourlay, B.J. Hawkins, A. Albert, J. Schnitzler, C. Peter Constabel, Condensed tannins as antioxidants that protect poplar against oxidative stress from drought and UV-B, *Plant Cell Environ* 45 (2022) 362–377, <https://doi.org/10.1111/pce.14242>.
- [51] D. Granato, D. Reshamwala, R. Korpinen, L. Azevedo, M.A. Vieira do Carmo, T. M. Cruz, M.B. Marques, M. Wen, L. Zhang, V. Marjomäki, P. Kilpeläinen, From the forest to the plate – Hemicelluloses, galactoglucomannan, glucuronoxylan, and phenolic-rich extracts from unconventional sources as functional food ingredients, *Food Chemistry* 381 (2022) 132284, <https://doi.org/10.1016/j.foodchem.2022.132284>.
- [52] W. Setyaningsih, I.E. Saputro, M. Palma, C.G. Barroso, Stability of 40 phenolic compounds during ultrasound-assisted extractions (UAE), in: *AIP conference proceedings*, Vol. 1755, No. 1, AIP Publishing, 2016, <https://doi.org/10.1063/1.4958517>.
- [53] J. Gabaston, T. Richard, B. Biais, P. Waffo-Teguo, E. Pedrot, M. Jourdes, M.-F. Corio-Costet, J.-M. Mérillon, Stilbenes from common spruce (*Picea abies*) bark as natural antifungal agent against downy mildew (*Plasmopara viticola*), *Ind Crops Prod* 103 (2017) 267–273, <https://doi.org/10.1016/j.indcrop.2017.04.009>.
- [54] E.S. Halmemies, H.E. Brännström, J. Nurmi, O. Läspä, R. Alén, Effect of Seasonal Storage on Single-Stem Bark Extractives of Norway Spruce (*Picea abies*), *Forests* 12 (2021) 736, <https://doi.org/10.3390/f12060736>.
- [55] L.M. Mattio, G. Catinella, S. Dallavalle, A. Pinto, Stilbenoids: A Natural Arsenal against Bacterial Pathogens, *Antibiotics* 9 (2020) 336, <https://doi.org/10.3390/antibiotics9060336>.
- [56] M. Le Normand, B. Rietzler, F. Vilaplana, M. Ek, Macromolecular Model of the Pectic Polysaccharides Isolated from the Bark of Norway Spruce (*Picea abies*), *Polymers* 13 (2021) 1106, <https://doi.org/10.3390/polym13071106>.
- [57] H. Kyllönen, A.S. Borisova, J. Heikkinen, P. Kilpeläinen, J. Rahikainen, C. Laine, Enzyme-assisted nanofiltration to enrich tannins from softwood bark extract, *Ind Crops Prod* 205 (2023) 117441, <https://doi.org/10.1016/j.indcrop.2023.117441>.
- [58] A. Scurria, M. Sciortino, A. Presentato, C. Lino, E. Piacenza, L. Albanese, F. Zabini, F. Meneguzzo, D. Nuzzo, M. Pagliaro, D.F. Chillura Martino, R. Alduina, G. Avellone, R. Ciriminna, Volatile Compounds of Lemon and Grapefruit IntegroPectin, *Molecules* 26 (2021) 51, <https://doi.org/10.3390/molecules26010051>.
- [59] J. Krogell, B. Holmbom, A. Pranovich, J. Hemming, S. Willför, Extraction and chemical characterization of Norway spruce inner and outer bark, *Nord Pulp Pap Res J* 27 (2012) 6–17, <https://doi.org/10.3183/npprj-2012-27-01-p006-017>.
- [60] L. Zhang, Q. Guan, J. Jiang, M.S. Khan, Tannin complexation with metal ions and its implication on human health, environment and industry: An overview, *Int J Biol Macromol* 253 (2023) 127485, <https://doi.org/10.1016/j.ijbiomac.2023.127485>.
- [61] A. Leone, C. Perone, A. Berardi, A. Tamborino, Energy analysis and numerical evaluation of the decanter centrifuge for wastewater management to allow a sustainable energy planning of the process, *Energy Convers Manag*: X 22 (2024) 100596, <https://doi.org/10.1016/j.ecmx.2024.100596>.
- [62] S. Szepessy, P. Thorwid, Low Energy Consumption of High-Speed Centrifuges, *Chem Eng Technol* 41 (2018) 2375–2384, <https://doi.org/10.1002/ceat.201800292>.
- [63] C.G.J. Baker, K.A. McKenzie, Energy Consumption of Industrial Spray Dryers, *Dry Technol* 23 (2005) 365–386, <https://doi.org/10.1081/DRT-200047665>.
- [64] C. Faraloni, L. Albanese, G. Chini Zittelli, F. Meneguzzo, L. Tagliavento, F. Zabini, New Route to the Production of Almond Beverages Using Hydrodynamic Cavitation, *Foods* 12 (2023) 935, <https://doi.org/10.3390/foods12050935>.
- [65] F. Meneguzzo, L. Albanese, C. Faraloni, C. Meneguzzo, L. Tagliavento, F. Zabini, Pilot Scale Tannin Extraction from Chestnut Wood Waste Using Hydrodynamic Cavitation, in: Y. Borgianni, D.T. Matt, M. Molinaro, G. Orzes (Eds.), *Towards a Smart, Resilient and Sustainable Industry*, Springer Nature Switzerland, Cham, 2023, pp. 437–447, https://doi.org/10.1007/978-3-031-38274-1_36.
- [66] J. Luo, G. Fu, W. Xu, Y. Zhai, L. Bai, J. Li, T. Qu, Experimental study on attenuation effect of liquid viscosity on shockwaves of cavitation bubbles collapse, *Ultrason Sonochem* 111 (2024) 107063, <https://doi.org/10.1016/j.ultsonch.2024.107063>.
- [67] W. Ding, F. Hong, D. Ying, Y. Huang, S. Nawaz Khan, J. Jia, A comprehensive study on the effects of annular protrusion for cavitation intensification in Venturi tubes, *Chem Eng J* 498 (2024) 155306, <https://doi.org/10.1016/j.cej.2024.155306>.
- [68] L. Albanese, R. Ciriminna, F. Meneguzzo, M. Pagliaro, Energy efficient inactivation of Saccharomyces cerevisiae via controlled hydrodynamic cavitation, *Energy Sci Eng* 3 (2015) 221–238, <https://doi.org/10.1002/ese3.62>.
- [69] D. Prat, A. Wells, J. Hayler, H. Sneddon, C.R. McElroy, S. Abou-Shehadeh, P.J. Dunn, CHEM21 selection guide of classical- and less classical-solvents, *Green Chem* 18 (2016) 288–296, <https://doi.org/10.1039/C5GC01008J>.

- [70] L.M. De Souza Mesquita, L.S. Contieri, F.A.E. Silva, R.H. Bagini, F.S. Bragagnolo, M.M. Strieder, F.H.B. Sosa, N. Schaeffer, M.G. Freire, S.P.M. Ventura, J.A. P. Coutinho, M.A. Rostagno, *Path2Green* : introducing 12 green extraction principles and a novel metric for assessing sustainability in biomass valorization, *Green Chem* 26 (2024) 10087–10106, <https://doi.org/10.1039/D4GC02512A>.
- [71] S. Rasi, P. Kilpeläinen, K. Rasa, R. Korpinen, J.-E. Raitanen, M. Vainio, V. Kitunen, H. Pulkkinen, T. Jyske, Cascade processing of softwood bark with hot water extraction, pyrolysis and anaerobic digestion, *Bioresour Technol* 292 (2019) 121893, <https://doi.org/10.1016/j.biortech.2019.121893>.
- [72] F. Weichmann, P. Rohdewald, Pycnogenol® French maritime pine bark extract in randomized, double-blind, placebo-controlled human clinical studies, *Front. Nutr.* 11 (2024) 1389374, <https://doi.org/10.3389/fnut.2024.1389374>.
- [73] O. Yesil Celiktas, M. Isleten, F. Vardar-Sukan, E. Oyku Cetin, *In vitro* release kinetics of pine bark extract enriched orange juice and the shelf stability, *British Food Journal* 112 (2010) 1063–1076, <https://doi.org/10.1108/00070701011080203>.
- [74] J. Masquelier, PROCESS FOR THE PREPARATION OF PURIFIED FLAVAN-3-OL POLYPHENOLIC EXTRACTS AND EXTRACTS OBTAINED, FR2643073B1, 1991. <https://patents.google.com/patent/FR2643073B1> (accessed November 7, 2024).
- [75] X. Yuan, Y. Liang, X. Hu, Y. Xu, Y. Chen, R. Kosonen, Waste heat recoveries in data centers: A review, *Renew Sustain Energy Rev* 188 (2023) 113777, <https://doi.org/10.1016/j.rser.2023.113777>.